

BIXOLON®

User's Manual

SRP-275III

Impact Printer

Rev. 1.01

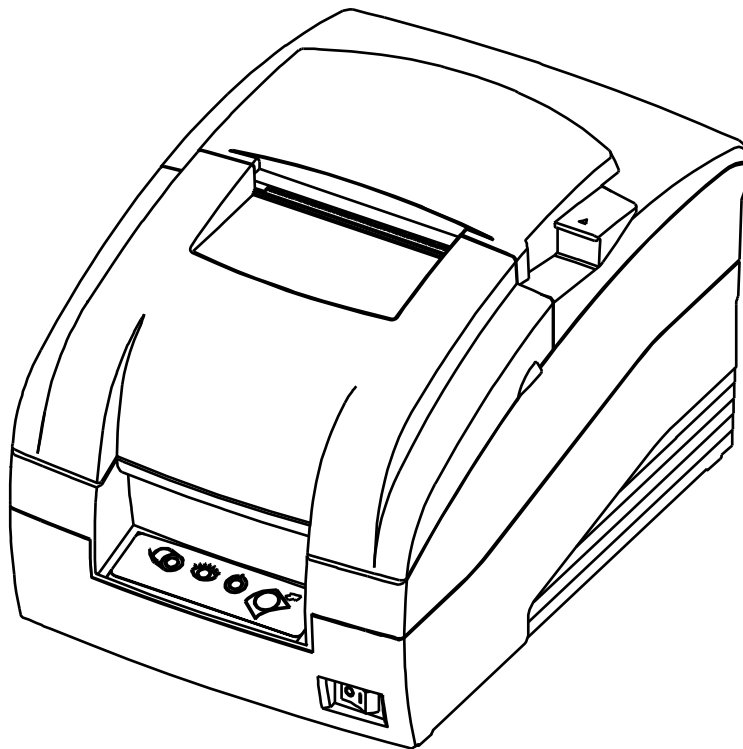

<http://www.bixolon.com>

■ Safety Precautions

In using the present appliance, please keep the following safety regulations in order to prevent any hazard or material damage.



WARNING

Violating following instructions can cause serious injury or death.

Do not plug several products in one multi-outlet.

- This can provoke over-heating and a fire.
- If the plug is wet or dirty, dry or wipe it before usage.
- If the plug does not fit perfectly with the outlet, do not plug in.
- Be sure to use only standardized multi-outlets.

PROHIBIT

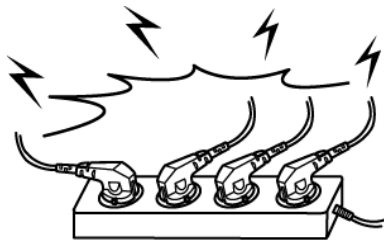

You must use only the supplied adapter.

- It is dangerous to use other adapters.

PROHIBIT



Do not pull the cable to unplug.

- This can damage the cable, which is the origin of a fire or a breakdown of the printer.

PROHIBIT

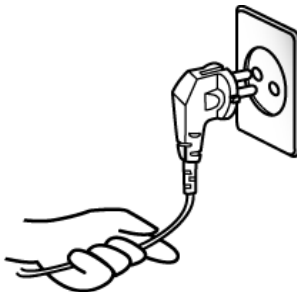

Keep the plastic bag out of children's reach.

- If not, a child may put the bag on his head.

PROHIBIT



Do not plug in or unplug with your hands wet.

- You can be electrocuted.

PROHIBIT

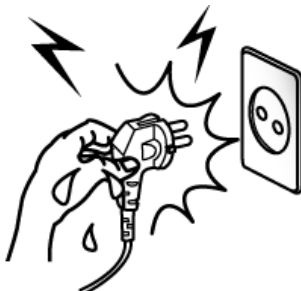

Do not bend the cable by force or leave it under any heavy object.

- A damaged cable can cause a fire.

PROHIBIT

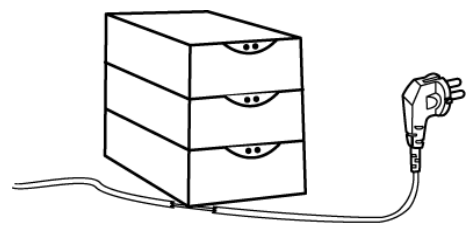



CAUTION

Violating following instructions can cause slight wound or damage the appliance.

If you observe a strange smoke, odor or noise from the printer, unplug it before taking following measures.

- Switch off the printer and unplug the set from the mains.
- After the disappearance of the smoke, call your dealer to repair it.

TO UNPLUG



Keep the desiccant out of children's reach.

- If not, they may eat it.

PROHIBIT



Install the printer on the stable surface.

- If the printer falls down, it can be broken and you can hurt yourself.

PROHIBIT

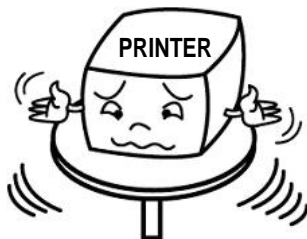

Use only approved accessories and do not try to disassemble, repair or remodel it for yourself.

- Call your dealer when you need these services.
- Do not touch the blade of auto cutter.

DISASSEMBLING PROHIBITED

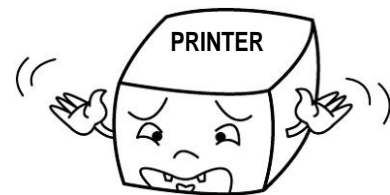

Do not let water or other foreign objects in the printer.

- If this happened, switch off and unplug the printer before calling your dealer.

PROHIBIT



Do not use the printer when it is out of order. This can cause a fire or an electrocution.

- Switch off and unplug the printer before calling your dealer.

TO UNPLUG



All rights reserved. No part of this publication may be reproduced, stored in a retrieval system, or transmitted in any form or by any means, electronic, mechanical, photocopying, recording, or otherwise, without the prior written permission of BIXOLON.

No patent liability is assumed with respect to the use of the information contained herein. While every precaution has been taken in the preparation of this book, BIXOLON assumes no responsibility for errors or omissions. Neither is any liability assumed for damages resulting from the use of the information contained herein.

Neither BIXOLON nor its affiliates shall be liable to the purchaser of this product or third parties for damages, losses, costs, or expenses incurred by purchaser or third parties as a result of: accident, misuse, or abuse of this product or unauthorized modifications, repairs, or alterations to this product, or (excluding the U.S.) failure to strictly comply with BIXOLON's operating and maintenance instructions.

BIXOLON shall not be liable against any damages or problems arising from the use of any options or any consumable products other than those designated as Original BIXOLON products.

■ Notice

We at BIXOLON maintain ongoing efforts to enhance and upgrade the functions and quality of all our products. In following, product specifications and/or user manual content may be changed without prior notice.

■ WARNING

The connection of a non-shielded printer interface cable to this printer will invalidate the EMC standards of this device. You are cautioned that changes or modifications not expressly approved by the party responsible for compliance could void your authority to operate the equipment.

■ Waste Electrical and Electric Equipment (WEEE)



This marking shown on the product or its literature, indicates that it should not be disposed with other household wastes at the end of its working life. To prevent possible harm to the environment or human health from uncontrolled waste disposal, please separate this from other types of wastes and recycle it responsibly to promote the sustainable reuse of material resources. Household users should contact either the retailer where they purchased this product, or their local government office, for details of where and how they can take this item for environmentally safe recycling. Business users should contact their supplier and check the terms and conditions of the purchase contract. This product should not be mixed with other commercial wastes for disposal.

■ Rating Label Symbol Information



DC (Direct current)

■ Label Material

- * Control Label: PC
- * Other Labels: PET

■ Introduction

The SRP-275III is a high-quality impact printer. This one-station printer has the following features.

- Compact design and light-weight.
- High-speed printing using logic-seeking (5.1LPS).
- Easy to use : Easy paper loading.
- High reliability and long life due to the use of stepping motors for head carriage return and paper feeding.
- Two color printing (red/black) available.
- The head can be driven due to the internal drawer interface.
- Character font (7 × 9, 9 × 9) is selectable.
- The auto cutter uses a circular method with a high-quality blade and a long life (Approximately 1,500,000 cuts).
- Default application of paper out sensor (not included with wall mount option).
- Black mark sensor function (front or rear option).
- A internal AC adaptor.

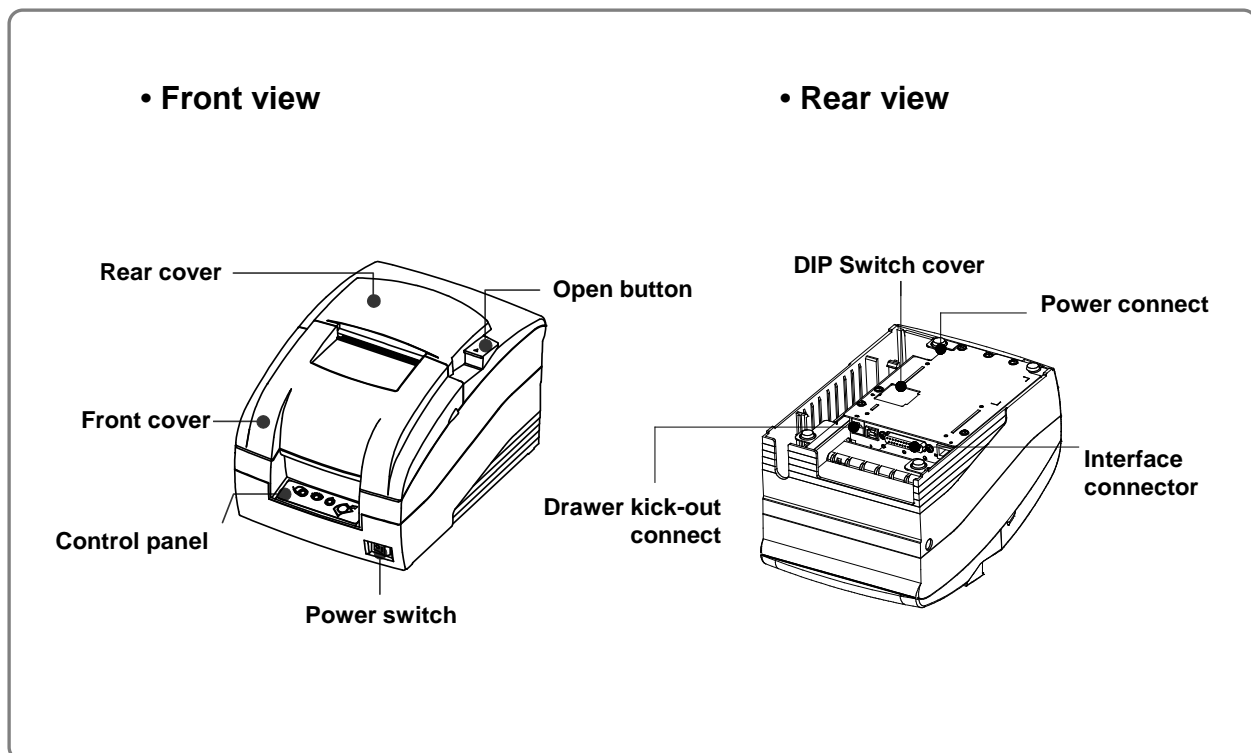

📌 NOTES

Please be sure to read the instructions in this manual carefully before using your new printer.

■ Table of Contents

1. Setting Up the Printer	8
1-1 Unpacking	8
1-2 Choosing a place for the printer	8
1-3 Using the operation panel.....	9
2. Connecting the cables	10
2-1 Connecting the AC Adaptor.....	10
2-2 Connecting the Interface cable and Drawer kick-out cable	10
2-2-1 Serial Interface (RS-232C) + Ethernet + USB : OES Model.....	11
2-2-2 Parallel Interface (IEEE1284) + USB : OP Model	12
2-2-3 Serial Interface (RS-232C) + USB : OS Model.....	13
2-2-4 Drawer kick-out	14
3. Setting the Switches	15
3-1 Setting the DIP Switch	15
3-1-1 DIP Switch setting for Citizen(iDP 3550) mode	16
3-1-2 DIP Switch setting for Star(SP500) mode.....	17
3-1-3 Changing the DIP Switch setting.....	18
3-2 Setting the Memory Switches	19
3-2-1 Memory Switch setting for Star mode.....	21
4. Ribbon Cassette Installation	27
5. Roll Paper Installation	28
6. Installing the wall mount (Option)	29
7. Self Test	30
8. Hexadecimal Dumping	31
9. Specification	32
9-1 Printing specification.....	32
9-2 Paper specifications	32
9-3 Ribbon cassette specification	32
9-4 Electrical characteristics	33
9-5 Reliability	33
9-6 Environment conditions	33
9-7 Dimensions & weight	34
9-8 Optional features	35
10. Appendix - Troubleshooting	36
10-1 ERROR LED blinking pattern.....	36
10-2 The printer does not start printing	37
10-3 The printer stops printing	38
10-4 You want to check the operation of the printer by itself	38
10-5 Printing is poor.....	38

1. Setting Up the Printer

1-1 Unpacking

Your printer box should include the items shown in the illustration below. If any items are damaged or missing, please contact your dealer.

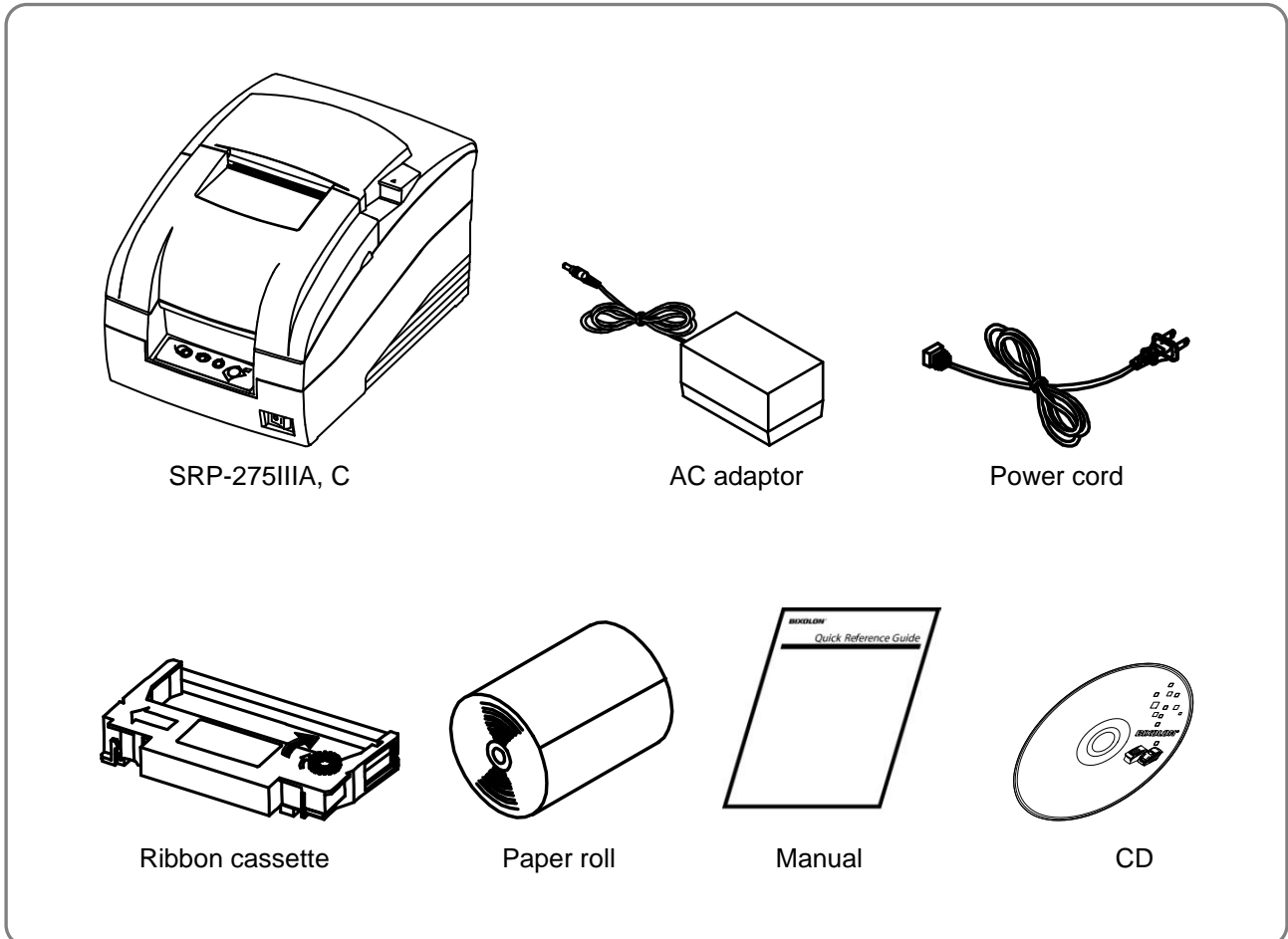

1-2 Choosing a place for the printer

- Avoid locations that are subject to direct sunlight or excessive heat.
- Avoid using or storing the printer in a place subject to excessive temperature or moisture.
- Do not use or store the printer in a dirty location.
- When setting up the printer, choose a stable, horizontal location.
- Intense vibration or shock may damage the printer.
- Ensure the printer has enough space to be used easily.

1-3 Using the operation panel

Most of the functions of this printer are governed by software, but you can monitor the printer's status by

looking at the lights on the control panel and for some procedures you will use the buttons.

- **Control panel**

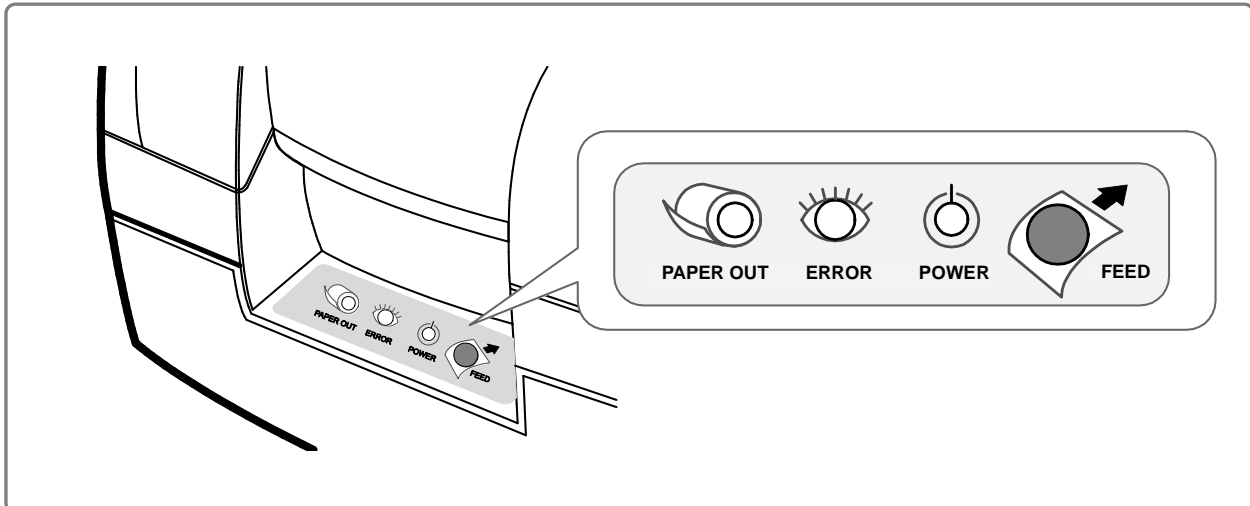

- **POWER LED (Green Color)**



This indicator light is on when the power is turned on.

- **ERROR LED (Red Color)**

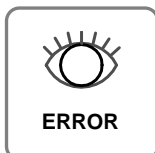

When this indicator light is on (but not blinking), it means that the printer is out of paper or almost out of paper or the printer covers are open. When this light is blinking, there is an error. (See "ERROR LED blinking pattern" in Chapter 11.) If you see this light blinking, turn off the printer for a few seconds and then turn it back on. If the light is still blinking, call your supervisor or a service person.

- **PAPER OUT LED (Red Color, not included with wall mount option)**



When this indicator light is on, it means that the paper is near the end. Replace the new paper roll. When ERROR and PAPER OUT indicator lights are on, it means paper end. Install the paper roll. (See "Installing paper roll" in Chapter 5.)

- **FEED button**



Use this button to feed paper or to start self test and for hexadecimal dump mode. (See the instructions "Self test" (8) in this chapter for self test.) (See the instructions "Hexadecimal dump" in Chapter 9 for hexadecimal dump mode.)

2. Connecting the cables

2-1 Connecting the AC Adaptor

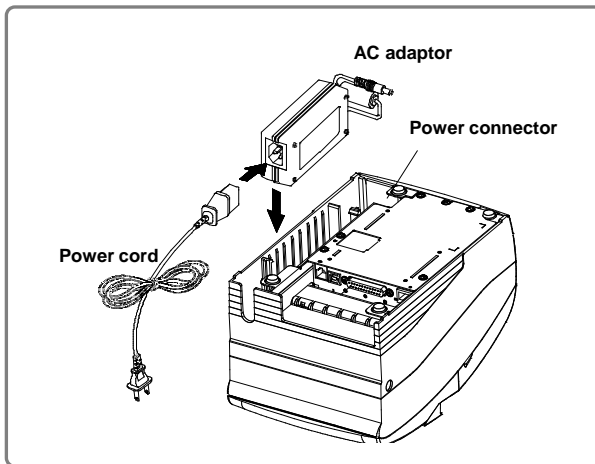

• **Connect the AC adaptor according to the following procedure.**

- 1) Make sure the printer is turned off.
- 2) Before inserting the AC adaptor, connect the power cord.
- 3) Insert the AC adaptor as shown.
- 4) Plug the AC adaptor cable into the printer's power connector.
- 5) Plug the power cord into the outlet, and turn on the power.

⚠ CAUTION

Before connecting the printer to the power supply, make sure that the voltage and power specifications match the printer's requirements. Using an incorrect power supply can cause serious damage to the printer.

2-2 Connecting the Interface cable and Drawer kick-out cable

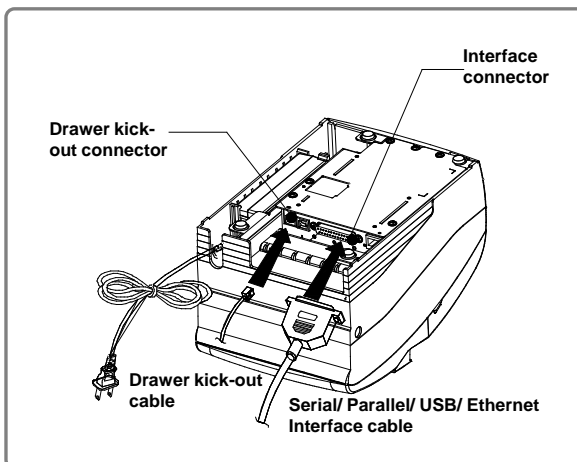

• **Connect the cables according to the following procedure.**

- 1) Turn off printer and the host ECR (host computer).
- 2) Plug the interface cable into the interface connector on the printer then fasten the screw on both sides of the connector.
- 3) Plug the drawer kick-out cable into the drawer kick-out connector on the printer. (When removing the drawer kick-out cable, press on the connector's clip while pulling out.)

📝 NOTES

Connect the printer to the host ECR (host computer) through an interface cable matching the specification of the printer and the host ECR (host computer). Be sure to use a drawer that matches the printer's specification.

Depending on the interface your system uses, either connect the serial, parallel, USB or Ethernet communication cable to the appropriate connector on the back of the printer. Cables are provided by your dealer or system installer.

2-2-1 Serial Interface (RS-232C) + Ethernet + USB : OES Model

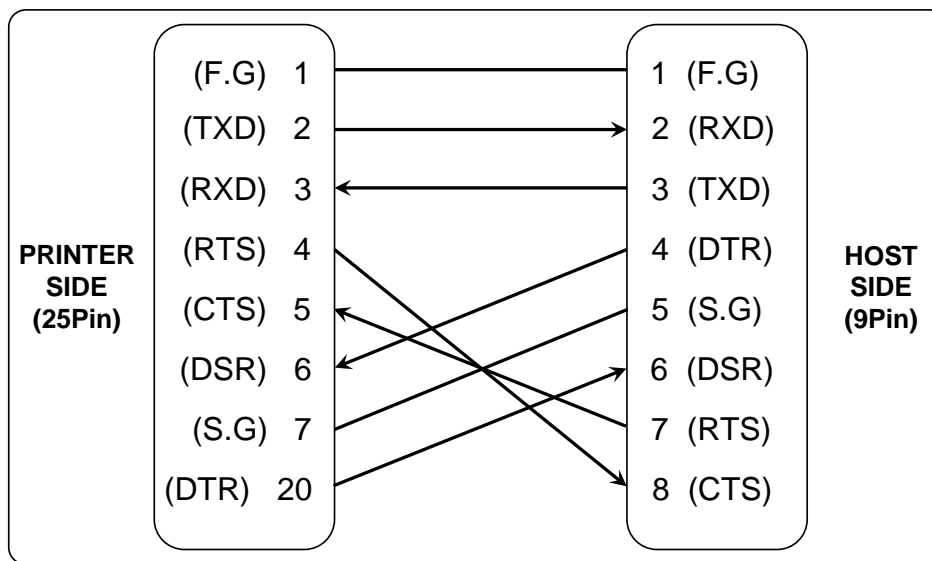
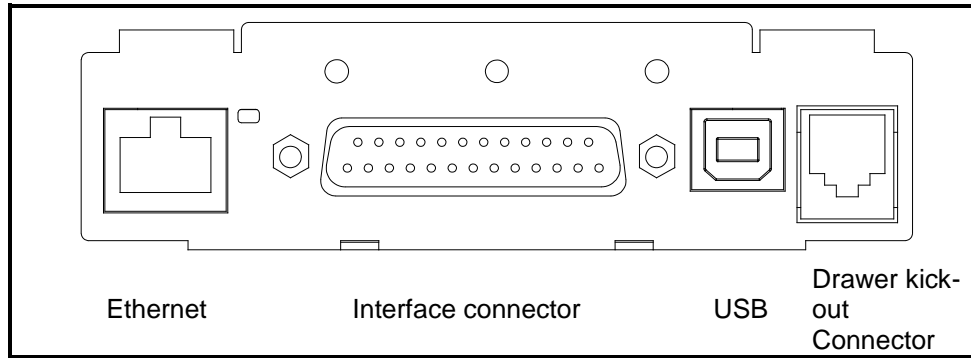

• **Serial**

Pin No.	Signal name	Direction	Function
1	FG	-	Frame Ground
2	TxD	Output	Transmit Data
3	RxD	Input	Receive Data
6	DSR	Input	Data Set Ready
7	SG	-	Signal Ground
20	DTR	Output	Data Terminal Ready

• **Ethernet**

Pin No.	Signal name	Assignment (Color)	Function
1	TxD+	White with orange stripe	Transmit +
2	TxD-	Solid orange	Transmit -
3	RxD+	White with green stripe	Receive +
4	NC	Solid blue	-
5	NC	White with blue stripe	-
6	RxD-	Solid green	Receive -
7	NC	White with brown stripe	-
8	NC	Solid brown	-

• **USB**

Pin No.	Signal name	Assignment (Color)	Function
Shell	Shield	Drain wire	Frame ground
1	VBUS	Red	NC
2	D-	White	Differential data line
3	D+	Green	Differential data line
4	GND	Black	Signal ground

2-2-2 Parallel Interface (IEEE1284) + USB : OP Model

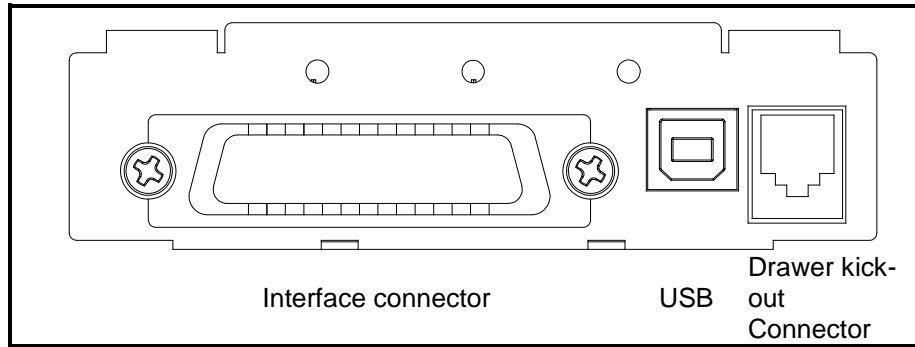

• **Parallel**

Pin no.	Source	Compatibility mode	Nibble mode	Byte mode
1	Host	nStrobe	HostClk	HostClk
2	Host / Printer	Data 0 (LSB)	-	Data 0 (LSB)
3	Host / Printer	Data 1	-	Data 1
4	Host / Printer	Data 2	-	Data 2
5	Host / Printer	Data 3	-	Data 3
6	Host / Printer	Data 4	-	Data 4
7	Host / Printer	Data 5	-	Data 5
8	Host / Printer	Data 6	-	Data 6
9	Host / Printer	Data 7 (MSB)	-	Data 7 (MSB)
10	Printer	nAck	PtrClk	PtrClk
11	Printer	Busy	PtrBusy / Data3,7	PtrBusy
12	Printer	Perror	AckDataReq / Data2,6	AckDataReq
13	Printer	Select	Xflag / Data1,5	Xflag
14	Host	nAutoFd	HostBusy	HostBusy
15	-	NC	ND	ND
16	-	GND	GND	GND
17	-	GND	FG	FG
18	Printer	Logic-H	Logic-H	Logic-H
19~30	-	GND	GND	GND
31	Host	nInit	nInit	nInit
32	Printer	nFault	nDataAbail /	nDataAvail
33	-	NC	ND	ND
34	Printer	NC	ND	ND
35	Printer	NC	ND	ND
36	Host	nSelectIn	1284-Active	1284-Active

• **USB**

Pin No.	Signal name	Assignment (Color)	Function
Shell	Shield	Drain wire	Frame ground
1	VBUS	Red	NC
2	D-	White	Differential data line
3	D+	Green	Differential data line
4	GND	Black	Signal ground

2-2-3 Serial Interface (RS-232C) + USB : OS Model

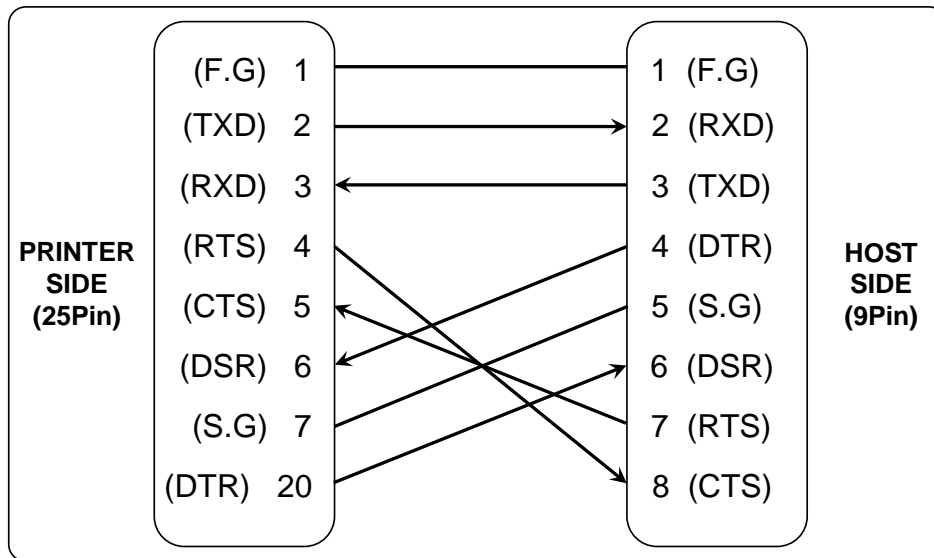
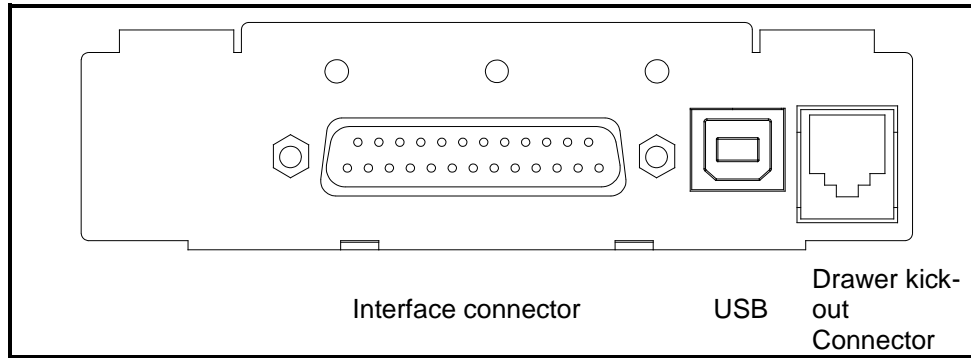

• **Serial**

Pin No.	Signal name	Direction	Function
1	FG	-	Frame Ground
2	TxD	Output	Transmit Data
3	RxD	Input	Receive Data
6	DSR	Input	Data Set Ready
7	SG	-	Signal Ground
20	DTR	Output	Data Terminal Ready

• **USB**

Pin No.	Signal name	Assignment (Color)	Function
Shell	Shield	Drain wire	Frame ground
1	VBUS	Red	NC
2	D-	White	Differential data line
3	D+	Green	Differential data line
4	GND	Black	Signal ground

2-2-4 Drawer kick-out

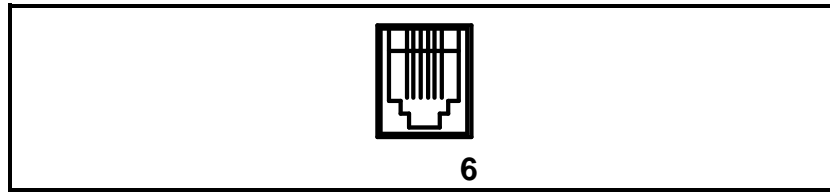

Pin No.	Description	Direction
1	Signal GND	-
2	Drawer kick-out driver signal #1	Output
3	Drawer Open / Close signal	Input
4	+24V	-
5	Drawer kick-out driver signal #2	Output
6	Signal GND	-

3. Setting the Switches

3-1 Setting the DIP Switch

Although the factory settings are best for almost all users, if you have special requirements, you can change the DIP Switch. Your printer has two sets of DIP Switches. The functions of the switches are shown in the following table.

• DIP Switch 1

Switch	Function	ON	OFF	Default
1-1	Emulation Selection (*1)	Refer to the following table		OFF
1-2				
1-3	Auto cutter	Enable	Disable	ON
1-4	Compatible with SRP-275	Enable	Disable	OFF
1-5	Serial interface selection	Memory Switch	DIP Switch	OFF
1-6	Print NV bit image #1 after cutting	Enable	Disable	OFF
1-7	Near end switch	Enable	Disable	ON
1-8	Printing column	42	40	OFF

• DIP Switch 2 (RS232C serial interface model)

Switch	Function	ON	OFF	Default
2-1	Data receive error	Ignore	Print “?”	OFF
2-2	Black Mark Sensor	Enable	Disable	OFF
2-3	Hand shaking	XON/XOFF	DTR/DSR	OFF
2-4	Word length	7 bits	8 bits	OFF
2-5	Parity check	Enable	Disable	OFF
2-6	Parity selection	EVEN	ODD	OFF
2-7	Baud rate selection (*2)	Refer to the following table		OFF
2-8				OFF

• DIP Switch 2 (Parallel interface model)

Switch	Function	ON	OFF	Default
2-1	Auto Line Feed	Enable	Disable	OFF
2-2	Black Mark Sensor	Enable	Disable	OFF
2-3~8	Undefined			OFF

NOTES

(*1) Emulation Selection (DSW 1-1 and 1-2)

Emulation	1-1	1-2
BXL/POS	OFF	OFF
BXL/POS-KP	ON	ON
STAR	OFF	ON
CITIZEN	ON	OFF

- BXL/POS-KP(Kitchen Printer mode) : A alarm is generated by printer after auto cutting and in paper end error.

(*2) Baud rate selection (Transmission speed)

Transmission	2-7	2-8
2400 baud	ON	ON
4800 baud	OFF	ON
9600 baud	OFF	OFF
19200 baud	ON	OFF

3-1-1 DIP Switch setting for Citizen(iDP 3550) mode

• **DIP Switch 1**

Switch	Function	ON	OFF	Default
1-1	Emulation Selection (*1)	Refer to the following table		OFF
1-2				
1-3	Auto cutter	Enable	Disable	OFF
1-4	CBM command	CBM2 mode (iDP3530 system)	CBM1 mode (iDP3540 system)	OFF
1-5	International characters (*2)	Refer to the following table		ON
1-6				
1-7				
1-8	CR mode	CR	CR+LF	OFF

• **DIP Switch 2 (RS232C serial interface model)**

Switch	Function	ON	OFF	Default
2-1	Word length	8 bits	7 bits	ON
2-2	Parity check	Disable	Enable	ON
2-3	Parity selection	ODD	EVEN	ON
2-4	Hand shaking	DTR/DSR	XON/XOFF	ON
2-5	Baud rate selection (*3)	Refer to the following table		OFF
2-6				
2-7	Near end switch	Enable	Disable	OFF
2-8	Mechanism type	Graphic	Character	OFF

 **NOTES**

(*1) Emulation Selection (DSW 1-1 and 1-2)

Emulation	1-1	1-2
BXL/POS	OFF	OFF
BXL/POS-KP	ON	ON
STAR	OFF	ON
CITIZEN	ON	OFF

- BXL/POS-KP(Kitchen Printer mode) : A alarm is generated by printer after auto cutting and in paper end error.

(*2) International Character Selection

Country	No.	DSW 1-5	DSW 1-6	DSW 1-7	Code page
U.S.A.		ON	ON	ON	Page 0 (PC437 : U.S.A.)
France		OFF	ON	ON	Page 2 (PC850 : Multilingual)
Germany		ON	OFF	ON	
U.K.		OFF	OFF	ON	
Denmark		ON	ON	OFF	Page 5 (PC865 : Nordic)
Sweden		OFF	ON	OFF	
Italy		ON	OFF	OFF	Page 2 (PC850 : Multilingual)
Windows Code		OFF	OFF	OFF	Windows Code

(*3) Baud rate selection (Transmission speed)

Transmission	2-5	2-6
2400 baud	ON	ON
4800 baud	OFF	ON
9600 baud	OFF	OFF
19200 baud	ON	OFF

3-1-2 DIP Switch setting for Star(SP500) mode

• **DIP Switch 1**

Switch	Function	ON	OFF	Default
1-1	Emulation Selection (*1)	Refer to the following table		OFF
1-2				
1-3	Auto cutter	Enable	Disable	OFF
1-4	Black/Red Printing	Enable	Disable	OFF
1-5	Reserved			OFF
1-6				
1-7				
1-8				

• **DIP Switch 2 (RS232C serial interface model)**

Switch	Function	ON	OFF	Default
2-1	Reserved			OFF
2-2				
2-3	Hand shaking	XON/XOFF	DTR/DSR	OFF
2-4	Word length	7 bits	8 bits	OFF
2-5	Parity check	Enable	Disable	OFF
2-6	Parity selection	EVEN	ODD	OFF
2-7	Baud rate selection (*2)	Refer to the following table		OFF
2-8				OFF

 **NOTES**

(*1) Emulation Selection (DSW 1-1 and 1-2)

Emulation	1-1	1-2
BXL/POS	OFF	OFF
BXL/POS-KP	ON	ON
STAR	OFF	ON
CITIZEN	ON	OFF

- BXL/POS-KP(Kitchen Printer mode) : A alarm is generated by printer after auto cutting and in paper end error.

(*2) Baud rate selection (Transmission speed)

Transmission	2-7	2-8
2400 baud	ON	ON
4800 baud	OFF	ON
9600 baud	OFF	OFF
19200 baud	ON	OFF

 **NOTICE**

Change in DIP Switch settings are recognized only when the printer power is turned on or when the printer is reset by using the interface. If the DIP Switch setting is changed after the printer power is turned on, the change does not take effect until the printer is turned on again or is reset.

3-1-3 Changing the DIP Switch setting

If you need to change settings, follow the steps below to make your changes.

⚠ CAUTION

Turn off the printer before removing the DIP Switch cover to prevent an electric short, which can damage the printer.

- 1) Make sure the printer is turned off.
- 2) Remove the screw from the DIP Switch cover.
Then take off the DIP Switch cover, which is shown in the illustration below.
- 3) Set the switches using a pointed tool, such as tweezers or a small.
- 4) Replace the DIP Switch cover. Then secure it with the screw.

📝 NOTES

The new settings take effect when you turn on the printer.

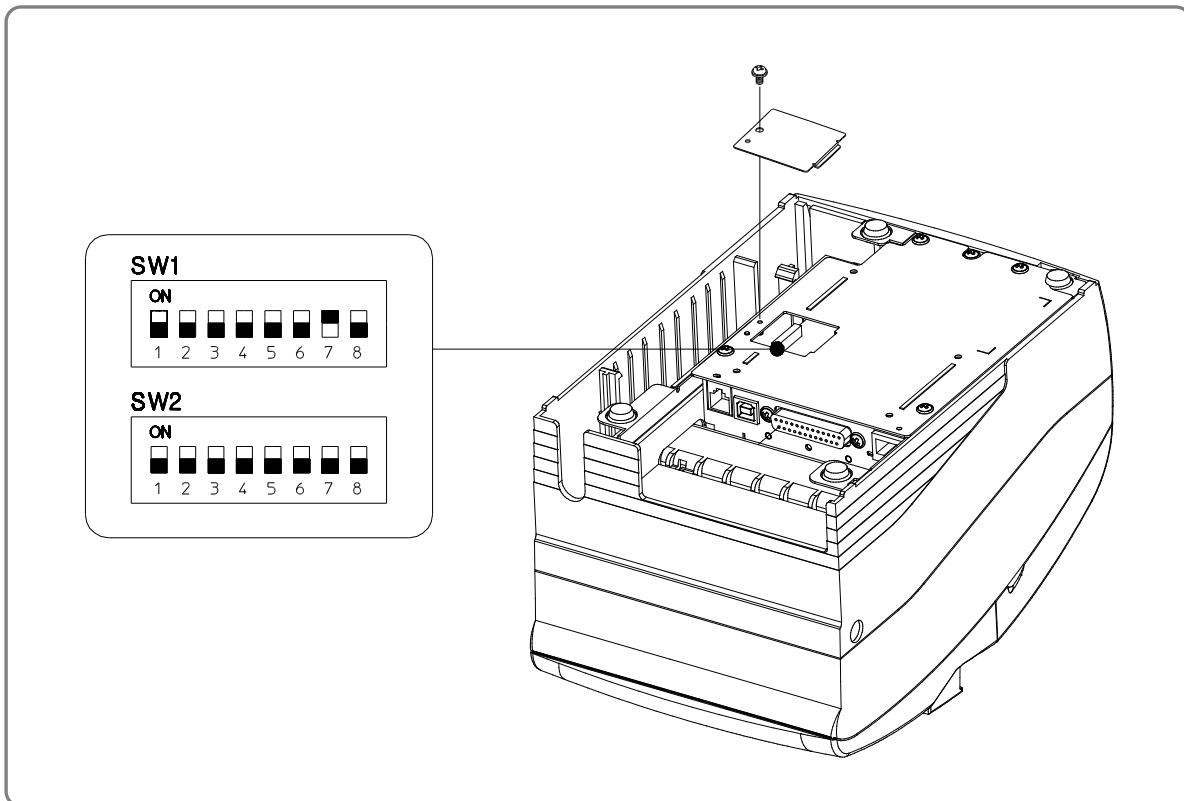

3-2 Setting the Memory Switches

This printer has “Memory Switch” set which is software switches. Memory Switch set has “MSW 2”, “MSW 8”, “Customize value”, “Serial communication condition”. “Memory Switch setting utility” can change the Memory Switch set to ON or OFF as shown in the table below (default: all OFF):

 **NOTES**

The Memory Switch is available to be changed by two methods:

- Memory Switch setting utility
- Control from command

Settings of the Memory Switch are stored in the NV memory; therefore, even if the printer is turned off, the settings are maintained.

• **Memory Switch 2**

Switch	Function	On	Off
1	Internal Buzzer Enable / Disable	Disable	Enable
2	External Buzzer Enable / Disable	Enable	Disable
3	Reserved	-	Fixed to Off
4~8	Code page selection (*1)	Refer to the following table	

 **NOTES**

Desired code page can be selected using Memory Switch 2-4~8 by setting as following.

(*1) Code page selection

MSW 2-8	MSW 2-7	MSW 2-6	MSW 2-5	MSW 2-4	Character Table
0	0	0	0	0	Page 0 (PC437 : U.S.A.)
0	0	0	0	1	Page 1 (Katakana)
0	0	0	1	0	Page 2 (PC850 : Multilingual)
0	0	0	1	1	Page 3 (PC860 : Portuguese)
0	0	1	0	0	Page 4 (PC863 : Canadian-French)
0	0	1	0	1	Page 5 (PC865 : Nordic)
0	0	1	1	0	Page 16 (WPC1252 : Latin1)
0	0	1	1	1	Page 17 (PC866 : Russian)
0	1	0	0	0	Page 18 (PC852 : Latin2)
0	1	0	0	1	Page 19 (PC858 : Euro)
0	1	0	1	0	Page 21 (PC862 : Israel)
0	1	0	1	1	Page 22 (PC864 : Arabic)
0	1	1	0	0	Page 23 (Thai character code 42)
0	1	1	0	1	Page 24 (WPC1253 : Greek)
0	1	1	1	0	Page 25 (WPC1254 : Turkish)
0	1	1	1	1	Page 26 (WPC1257 : Baltic)
1	0	0	0	0	Page 27 (Farsi) (*2)
1	0	0	0	1	Page 28 (WPC1251 : Russian) (*2)
1	0	0	1	0	Page 29 (PC737 : Greek) (*2)
1	0	0	1	1	Page 30 (PC775 : Baltic) (*2)
1	0	1	0	0	Page 31 (Thai character code 14)
1	0	1	0	1	Page 32 (OldCode : Israel)
1	0	1	1	0	Page 33 (WPC1255 : Israel)
1	0	1	1	1	Page 34 (Thai character code 11)
1	1	0	0	0	Page 35 (Thai character code 18)
1	1	0	1	0	Page 37 (PC857 : Turkish)
1	1	0	1	1	Page 38 (PC928 : Greek)
1	1	1	1	0	Page 41 (WPC1258 : Vietnam)

(*2) Only Font B available.

• Memory Switch 8

Switch	Function	On	Off
1	Upside down	On	Off
2	Font Selection	Font B	Font A
3	Selection Paper End Buzzer	Off	On
4~5	Reserved	Fixed to Off	

• Serial communication

Function	Selectable value
Modulation rate	2400 bps, 4800 bps, 9600 bps, 19200 bps
Parity	None, Odd, Even, -
Handshake	DSR/DTR, XON/XOFF
Data length	7 bit, 8 bit

 NOTES

There are two methods, DIP Switch and Memory Switch, to adjust the serial communication conditions.

DIP Switch 1-5 selects which is effective, DIP Switch or Memory Switch.

To enable the “Serial communication” setting, you have to adjust the “Serial interface selection” function of DIP Switch 1-5 to “Memory Switch”.

3-2-1 Memory Switch setting for Star mode

• Settings

Memory Switches are from MSW 0 to MSW 8. They are stored in non-volatile memory (flash memory). To change the settings, send the following commands from the host.

[Name] Set Memory Switch
 [Code] ASCII ESC GS # *m {n1 n2 n3 0n4}₀ ... {n1 n2 n3 n4}₈* LF NUL
 Hexadecimal 1B 1D 23 *m {n1 n2 n3 0n4}₀ ... {n1 n2 n3 n4}₈* 0A 00
 Decimal 27 29 35 *m {n1 n2 n3 0n4}₀ ... {n1 n2 n3 n4}₈* 10 0
 [Defined Region] *m* = "W", "T", ",", "+", "-", "@"
 "0" ≤ *n1,n2,n3,n4* ≤ "9",
 "A" ≤ *n1,n2,n3,n4* ≤ "F"
 [Function] Sends command to write after defining Memory Switch using the definition command specified by the following classes to set the Memory Switch. The printer is automatically reset after writing the setting defined by that command to the non-volatile memory.
 Do not turn off the power to the printer while sending commands to the non volatile memory. Doing so will destroy the Memory Switch setting. It is also possible for all Memory Switch settings to become offset to their initial, default settings.
 Consider the life of the non-volatile memory and avoid over-use of this command.

Function	Class	<i>m</i>	<i>{n1 n2 n3 0n4}₀ ... {n1 n2 n3 n4}₈</i>
Data Definition (Data Specification)	Definition	","	<i>{n1 n2 n3 0n4}₀ ... {n1 n2 n3 n4}₈</i>
Data definition (set specified bit)	Definition	"+"	<i>{n1 n2 n3 0n4}₀ ... {n1 n2 n3 n4}₈</i>
Data definition (clear specified bit)	Definition	"-"	<i>{n1 n2 n3 0n4}₀ ... {n1 n2 n3 n4}₈</i>
Data Definition (clear all data)	Definition	"@"	Fixed at "0000"
Definition data write and reset	Write	"W"	Fixed at "0000"
Definition data write and reset and test print	Write	"T"	Fixed at "0000"

(Ex) Memory Switch 1-8 = 0; Memory Switch 2-7 = 1; Memory Switch 2-A = 1 for a test print:
 PRINT #1, CHR\$(&H1B);CHR\$(&H1D);CHR\$(&H23);CHR\$(&H2D); ' <ESC><GS> # -
 PRINT #1, CHR\$(&H30);CHR\$(&H30);CHR\$(&H30);CHR\$(&H30); ' 0000
 PRINT #1, CHR\$(&H30);CHR\$(&H31);CHR\$(&H30);CHR\$(&H30); ' 0100
 PRINT #1, CHR\$(&H30);CHR\$(&H30);CHR\$(&H30);CHR\$(&H30); ' 0000
 PRINT #1, CHR\$(&H30);CHR\$(&H30);CHR\$(&H30);CHR\$(&H30); ' 0000
 PRINT #1, CHR\$(&H30);CHR\$(&H30);CHR\$(&H30);CHR\$(&H30); ' 0000
 PRINT #1, CHR\$(&H30);CHR\$(&H30);CHR\$(&H30);CHR\$(&H30); ' 0000
 PRINT #1, CHR\$(&H30);CHR\$(&H30);CHR\$(&H30);CHR\$(&H30); ' 0000
 PRINT #1, CHR\$(&H30);CHR\$(&H30);CHR\$(&H30);CHR\$(&H30); ' 0000
 PRINT #1, CHR\$(&H30);CHR\$(&H30);CHR\$(&H30);CHR\$(&H30);CHR\$(&H0A);CHR\$(0); ' 0000
 <LF><NUL>
 PRINT #1, CHR\$(&H1B);CHR\$(&H1D);CHR\$(&H23);CHR\$(&H2B); ' <ESC><GS> # +
 PRINT #1, CHR\$(&H30);CHR\$(&H30);CHR\$(&H30);CHR\$(&H30); ' 0000
 PRINT #1, CHR\$(&H30);CHR\$(&H30);CHR\$(&H30);CHR\$(&H30); ' 0000
 PRINT #1, CHR\$(&H30);CHR\$(&H34);CHR\$(&H38);CHR\$(&H30); ' 0480
 PRINT #1, CHR\$(&H30);CHR\$(&H30);CHR\$(&H30);CHR\$(&H30); ' 0000
 PRINT #1, CHR\$(&H30);CHR\$(&H30);CHR\$(&H30);CHR\$(&H30); ' 0000
 PRINT #1, CHR\$(&H30);CHR\$(&H30);CHR\$(&H30);CHR\$(&H30); ' 0000
 PRINT #1, CHR\$(&H30);CHR\$(&H30);CHR\$(&H30);CHR\$(&H30); ' 0000
 PRINT #1, CHR\$(&H30);CHR\$(&H30);CHR\$(&H30);CHR\$(&H30); ' 0000
 PRINT #1, CHR\$(&H30);CHR\$(&H30);CHR\$(&H30);CHR\$(&H30);CHR\$(&H0A);CHR\$(0); '
 0000<LF><NUL>
 PRINT #1, CHR\$(&H1B);CHR\$(&H1D);CHR\$(&H23);CHR\$(&H54); ' <ESC><GS> # T
 PRINT #1, CHR\$(&H30);CHR\$(&H30);CHR\$(&H30);CHR\$(&H30);CHR\$(&H0A);CHR\$(&H0); ' 0000
 <LF><NUL>

• Default Settings

The default settings for Memory Switch 0 to Memory Switch 8 are shown below. Settings vary for single byte character countries (standard specifications (SBCS)) and for double-byte character countries (Chinese character specifications (DBCS)).

- Standard Specifications (SBCS)

Memory Switch Number	Ex-factory Settings (n1, n2, n3, n4)
MSW 0	"0000"
MSW 1	"0000"
MSW 2	"0000"
MSW 3	"0000"
MSW 4	"0000"
MSW 5	"0000"
MSW 6	"0000"
MSW 7	"0000"
MSW 8	"0000"

- Chinese character specifications (DBCS) (For China)

Memory Switch Number	Ex-factory Settings (n1, n2, n3, n4)
MSW 0	"0010"
MSW 1	"0000"
MSW 2	"0000"
MSW 3	"0000"
MSW 4	"0000"
MSW 5	"0000"
MSW 6	"0000"
MSW 7	"0000"
MSW 8	"0000"

• Function
- Memory Switch 0

Bit	Function	0	1
F~C	Reserved	Fixed to Off	
B~A	Red and Black (inverted black and white) Commands (*3)	Refer to the following table	
9~5	Reserved		
4	Country Specifications (*1)	SBCS (Single Byte countries)	DBCS (Double Byte countries)
3~2	<FF> Command (*2)	Refer to the following table	
1~0	Reserved	Fixed to Off	

NOTES

(*1) Country Specifications

Country	MSW 0-4 = 0	MSW 0-4 = 1
Overseas	Standard Specifications	Chinese Characters

(*2) <FF> Command Function Selection

MSW 0-3	MSW 0-2	<FF> Command Function	<FF> Command Function
Auto cutter model		Tear Bar Model (SRP-275III A type)	
0	0	Executes a form feed.	Executes a form feed.
0	1	After paper fed to cutting position executes partial cut (*3)	Paper fed to the tear-bar position
1	0	Executes a form feed.	Executes a form feed.
1	1	After paper fed to cutting position executes partial cut (*3)	Paper fed to the tear-bar position

(*3) Red and Black (inverted black and white) Commands

MSW 0-B	MSW 0-A	<ESC> 4 / <ESC> 5 Command Functions
0	0	White/black inverted printing (1 Pass)
0	1	<Option 1> White/black inversion (7 x 9 font print) + enhancing (2 passes)
1	0	<Option 2> Upper line + Underline + enhancing (2 passes)
1	1	<Option 3> Upper line + Underline + double tall expanded + enhancing (4 passes)

This setting functions to specify adornments when the subsequent red (white/black inversion) print command is set. It is a substitute function for the conventional red/black (white/black inversion) printing.

<ESC> “4”: Red (white/black inversion) printing

<ESC> “5”: Red (white/black inversion) printing cancelled.

When using <ESC> 5 to cancel adornments, it returns to the previously set adornments. (Adornments such as underline, upper line, double-tall expanded and enhancing are cancelled if there is no command to set them (for example the <ESC> “-” 1 specification for underlines).)

This setting is enabled only for ANK characters and block characters. It is disabled for IBM block characters and Chinese characters composed of 12 dot vertical characters (IBM block characters and Chinese characters do not have adornment with this command).

- Memory Switch 1

Bit	Function	0	1
F~5	Reserved	Fixed to Off	
E~5			
4	Zero style	Normal	Slash zero
3~0	International Characters (*1)	Refer to the following table	

 **NOTES**

(*1) International Characters Default Value Settings

MSW1-3	MSW1-2	MSW1-1	MSW1-0	International Characters
0	0	0	0	U.S.A
0	0	0	1	France
0	0	1	0	Germany
0	0	1	1	U.K.
0	1	0	0	Denmark1
0	1	0	1	Sweden
0	1	1	0	Italy
0	1	1	1	Spain1
1	0	0	0	Japan
1	0	0	1	Norway
1	0	1	0	Denmark2
1	0	1	1	PC-999

- Memory Switch 2

Bit	Function	0	1
F	Reserved	Fixed to Off	
E	How to recover to print ready after inserting paper	Press FEED.	Auto-recovery
D~4	Reserved	Fixed to Off	
3	Contextual auto-cut function (*1)	Disabled	Enabled
2			
1~0	Near end switch function (*2)	Refer to the following table	

 **NOTES**

(*1) Contextual Auto-cut Function

This function auto-cuts paper when a paper feed command that feeds continuously over 7/6 inch.

Hosts that cannot send an escape sequence, such as <ESC> “d” 0 can cut paper if a 1/6 inch line feed code <LF> is sent seven times.

(*2) Near end switch Function

When an near end switch is mounted, settings should abide by those shown in the table below.

MSW 2-1	MSW 2-0	Near end switch Function
0	0	Disabled
0	1	Disabled
1	0	Reflects the near end switch state to the status. Printing does not stop for near end, and the printer does not go offline.
1	1	Reflects the near end switch state to the status. Printing does stop for near end, and the printer goes offline.

- Memory Switch 3

Bit	Function	0	1
F~D	Reserved	Fixed to Off	
C~8	Character Table (*2)	Refer to the following table	
7~2	Reserved	Fixed to Off	
1~0	<CR> Command Functions (*1)	Refer to the following table	

NOTES

(*1) <CR> Command Functions

MSW3-1	MSW3-0 <CR>	Functions
0	0 Ignored	
0	1 Ignored	
1	0	Prints and performs a line feed (same as <LF>.)
1	1	Prints (No line feed)

(*2) Character Table Settings

These settings are enabled only on standard specification printers.

MSW3-C	MSW3-B	MSW3-A	MSW3-9	MSW3-8	Character Table
0	0	0	0	0	Page 0 (PC437 : U.S.A.)
0	0	0	0	1	Page 1 (Katakana)
0	0	0	1	0	Page 2 (PC850 : Multilingual)
0	0	0	1	1	Page 3 (PC860 : Portuguese)
0	0	1	0	0	Page 4 (PC863 : Canadian-French)
0	0	1	0	1	Page 5 (PC865 : Nordic)
0	0	1	1	0	Page 16 (WPC1252 : Latin1)
0	0	1	1	1	Page 17 (PC866 : Russian)
0	1	0	0	0	Page 18 (PC852 : Latin2)
0	1	0	0	1	Page 19 (PC858 : Euro)
0	1	0	1	0	Page 21 (PC862 : Israel)
0	1	0	1	1	Page 22 (PC864 : Arabic)
0	1	1	0	0	Page 23 (Thai character code 42)
0	1	1	0	1	Page 24 (WPC1253 : Greek)
0	1	1	1	0	Page 25 (WPC1254 : Turkish)
0	1	1	1	1	Page 26 (WPC1257 : Baltic)
1	0	0	0	0	Page 27 (Farsi) (*3)
1	0	0	0	1	Page 28 (WPC1251 : Russian) (*3)
1	0	0	1	0	Page 29 (PC737 : Greek) (*3)
0	0	0	1	1	Page 30 (PC775 : Baltic) (*3)
1	0	1	0	0	Page 31 (Thai character code 16)
1	0	1	0	1	Page 32 (OldCode : Israel)
1	0	1	1	0	Page 33 (WPC1255 : Israel)
1	0	1	1	1	Page 34 (Thai character code 11)
1	1	0	0	0	Page 35 (Thai character code 18)
1	1	1	0	0	Page 37 (PC857 : Turkish)
1	1	1	0	1	Page 38 (PC928 : Greek)
1	1	1	1	0	Page 41 (WPC1258 : Vietnam)

(*3) Only Font B available.

- Memory Switch 4

Bit	Function	0	1
F~1	Reserved	Fixed to Off	
0	Data reception error (serial)	Prints “?”	Ignored

- Memory Switch 5

Bit	Function	0	1
F~0	Reserved	Fixed to Off	

- Memory Switch 6

Bit	Function	0	1
F~0	Reserved	Fixed to Off	

- Memory Switch 7

Bit	Function	0	1
F~0	Reserved	Fixed to Off	

4. Ribbon Cassette Installation

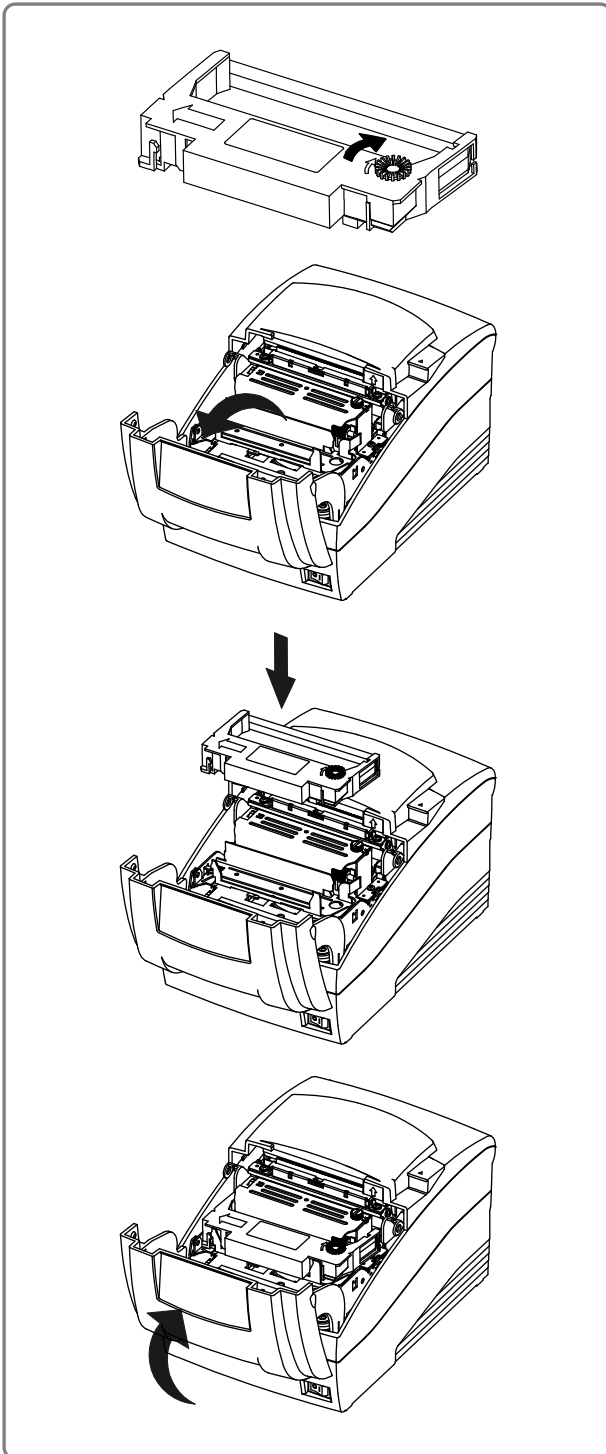

- 1) Before inserting the ribbon cassette, turn the knob clockwise to prevent twisting the ribbon.
- 2) Open the front cover of printer.
- 3) Take out the old ribbon cassette if there is one.
- 4) Insert the new ribbon cassette as shown and pay particular attention to the placement of the ribbon behind the Printer Head.
- 5) During inserting the ribbon cassette, turn the knob clockwise again to make sure the ribbon moves freely in the cassette.

NOTES

Using unauthorized ribbon cartridges may result in poor printing quality or malfunction and will void the warranty.

Refer to page 9-3 of the User Manual for the specifications of the supported ribbon cartridges.

5. Roll Paper Installation

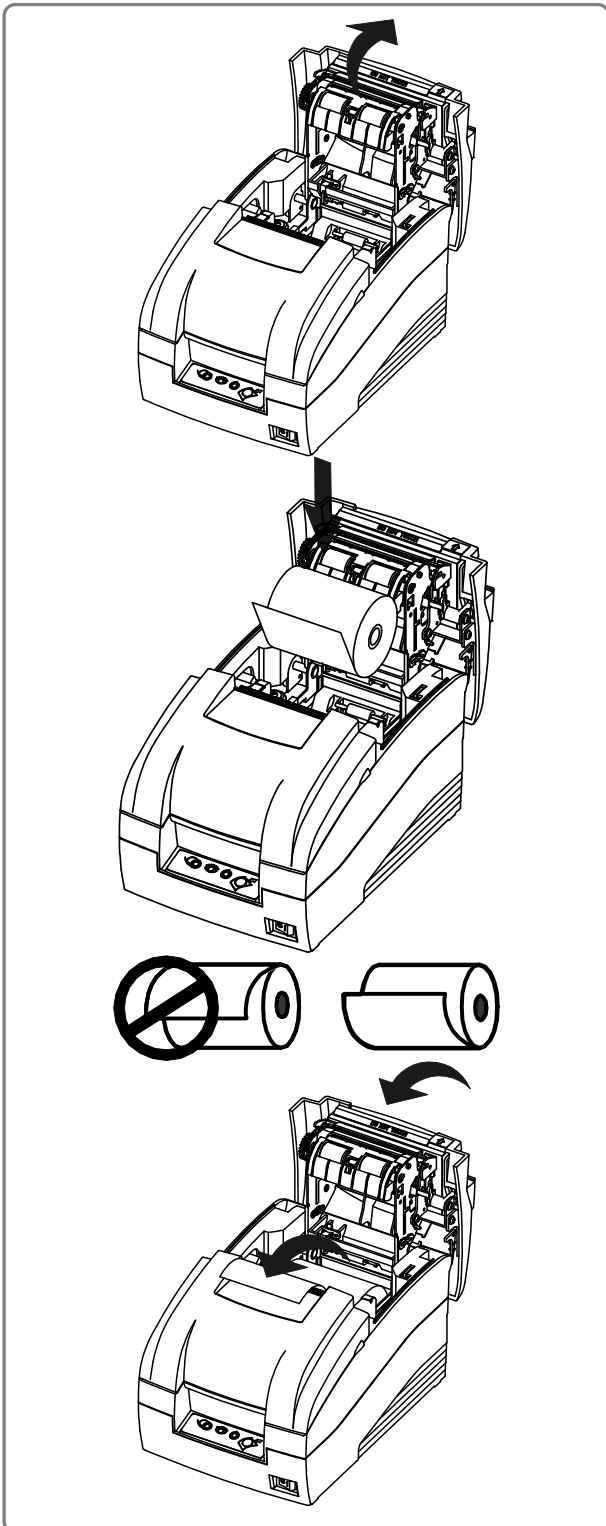

1) Open the rear cover by pushing the open button.

2) Remove the used paper roll core if there is one.

3) Insert the paper roll as shown.

4) Be sure to note the correct direction that the paper should come off the paper roll.

5) Pull out small amount of paper as shown. Then close the cover and tear off the extra paper by pulling it toward the front of the printer.

⚠ CAUTION

Do not touch the auto cutter blade when you open rear cover.

6. Installing the wall mount (Option)

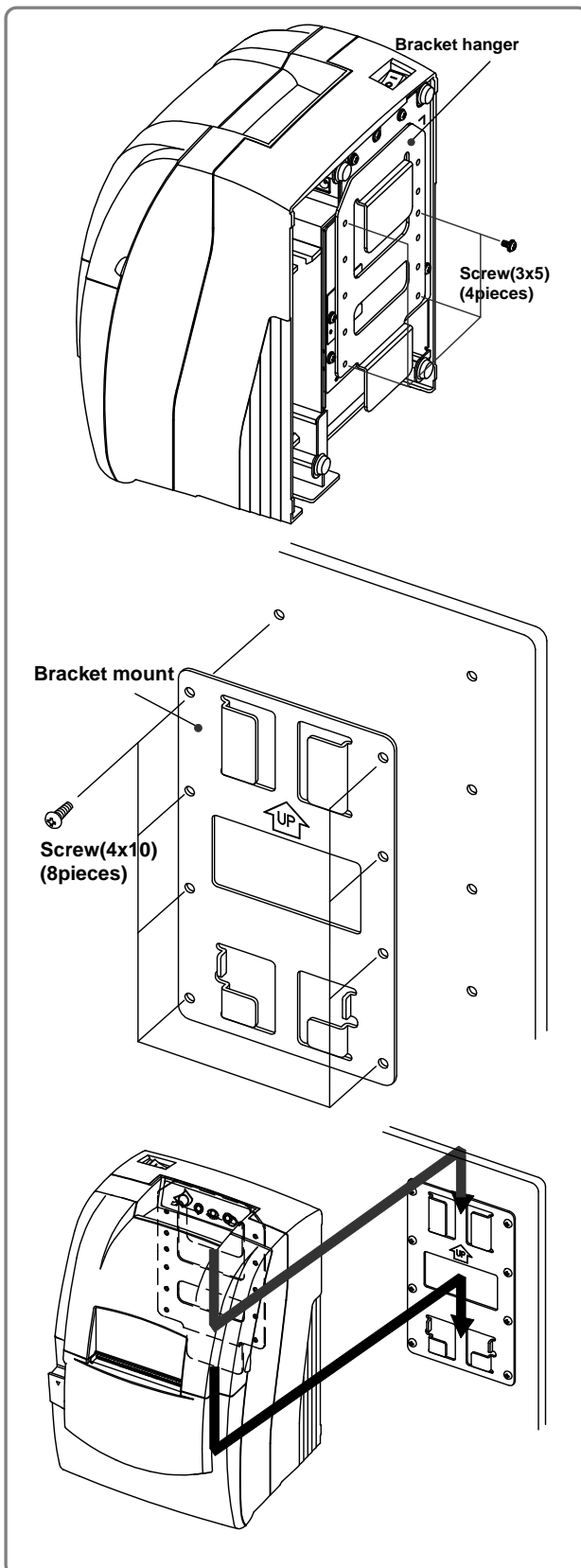

1) Turn the Set over and attach the Bracket hanger to the Frame base then tighten four screws.

2) Attach the Bracket mount to the wall firmly with the eight screws. Be sure that the Bracket attached properly to match the direction of arrow as shown. And the Bracket mount should be always fixed vertically.

3) Insert the Bracket hanger of Set to the Bracket mount as shown.

NOTES

Wall mount is an optional item. DIP switch 1-7 should be set to OFF because wall mount installation does not support Paper Out sensor. Contact seller or store you purchased the product from for detailed information on wall mount installation.

7. Self Test

The self test let you know if your printer is operating properly. It checks the printing quality, ROM version, DIP Switch settings, memory switch settings and statistic data.

The test is independent of any other equipment or software, so it is a good idea to run it when you first set up the printer or if you have any trouble. If the self test works correctly, the problem is in the other equipment or the software, not the printer.

• Running the self test

- 1) Make sure the printer is turned off and the printer cover is closed properly.
- 2) Turn on the power while pressing the Feed button and release the button, then the paper will feed. Self diagnostics will begin and printer settings will be printed. Paper will be cut upon completion of the test and printing will stop. (ERROR lamp will be on.)
- 3) Press the FEED button to continue printing the statistic data.
- 4) Press the FEED button to continue printing the rolling ASCII pattern.
- 5) The self test mode terminates after printing the rolling ASCII pattern automatically.

8. Hexadecimal Dumping

- **Hexadecimal dump**

This feature allows experienced users to see exactly what data is coming to the printer. This can be useful in finding software problems. When you turn on the hexadecimal dump function, the printer prints all commands and other data in hexadecimal format along with a guide section to help you find specific commands.

- **To use the hexadecimal dump feature, follow these steps:**

- 1) After you make sure that the printer is off, open the rear cover of the printer.
- 2) Hold down the FEED button while you turn on the printer.
- 3) Close the rear cover.
- 4) Run any software program that sends data to the printer. The printer prints "Hexadecimal dump" and then all the codes are received in a two column format. The first column contains the hexadecimal codes and the second column gives the ASCII characters that correspond to the codes.

```
Hexadecimal Dump
To terminate hexadecimal dump
Press FEED button three times

1B 21 00 1B 26 02 40 40 . ! . . & . @ @
1B 25 01 1B 63 34 00 1B . % . . c 4 . .
41 42 43 44 45 46 47 48 A B C D E F G H

<Online Hex Dump Completed>
```

(A period(.) is printed for each code that has no ASCII equivalent.)

- 5) When the printing finishes, turn off the printer.

9. Specification

9-1 Printing specification

Item	Description	Remark
Printing method	Serial impact method	
Head wire	9 pin serial type	
Dot pitch	0.352mm (1/72")	
Dot wire diameter	0.28mm (0.01")	
Printing direction	Bidirectional (logic seeking) with friction feed	
Characters per line	Max. 42 (characters)	
Printing speed	5.1 LPS (Line Per Second)	
Printing width	63.5 mm	
Line interval	4.233 mm (1/6")	
Paper feed method	Friction feed	
Paper feed speed	Approximately 158 mm (6.2")	
Character font	7 x 9 / 9 x 9	
Character sets	Alphanumeric characters : 95 International characters : 48 Extended graphics : 128 x 27 pages	

9-2 Paper specifications

Item	Description	Remark
Paper type	Paper roll	
Paper roll width	76±0.5 mm	
Paper roll diameter	Max. ø83 mm (3.27")	
Normal paper	Thickness : 1 sheet 0.06~0.085 mm (0.0024~0.0034") Weight : 52.3~64g/m ² (0.115~0.1411 lb)	
Paper core outside diameter	Max. ø19mm (0.75")	

9-3 Ribbon cassette specification

Item	Description	Remark
Standard	GRC-201BR	
Color	Black & Red	
Size	13 mm (W)	
Life	GRC-201BR : 1,500,000 characters (Black) 750,000 characters (Red)	Continuous printing 7x9 font ASCII 25°C

NOTES

Using unauthorized ribbon cartridges may result in poor printing quality or malfunction and will void the warranty.

9-4 Electrical characteristics

Item		Description	Remark
SMPS Supply voltage		24VDC	
Current consumption (at 24V, except for drawer kick-out driving)	Operating	Mean : Approximately 0.5A Peak : Approximately 1.5A	
	Standby	Mean: Approximately 0.3A	

 **NOTES**

Maximum 1A for drawer kick-out driving.

9-5 Reliability

Item	Description	Remark
Life firing frequency	Mechanism : Approx. 18 million lines Auto cutter : Approx. 1.5 million cuts (End of life is defined as the point at which the printer reaches the beginning of the Wear out Period.)	
Head	Approx. 300 million dots/wire	

9-6 Environment conditions

Item	Description	Remark
Temperature	Operating : 0~40°C (32~104°F) Storage : -20~60°C (-4~140°F)	
Relative humidity	Operating : 10~80% RH (Non-condensing) Storage : 10~90% RH (Non-condensing)	

 **NOTES**

This equipment is indooruse and all the communication hiring are limited to inside of the building.

9-7 Dimensions & weight

• Dimensions

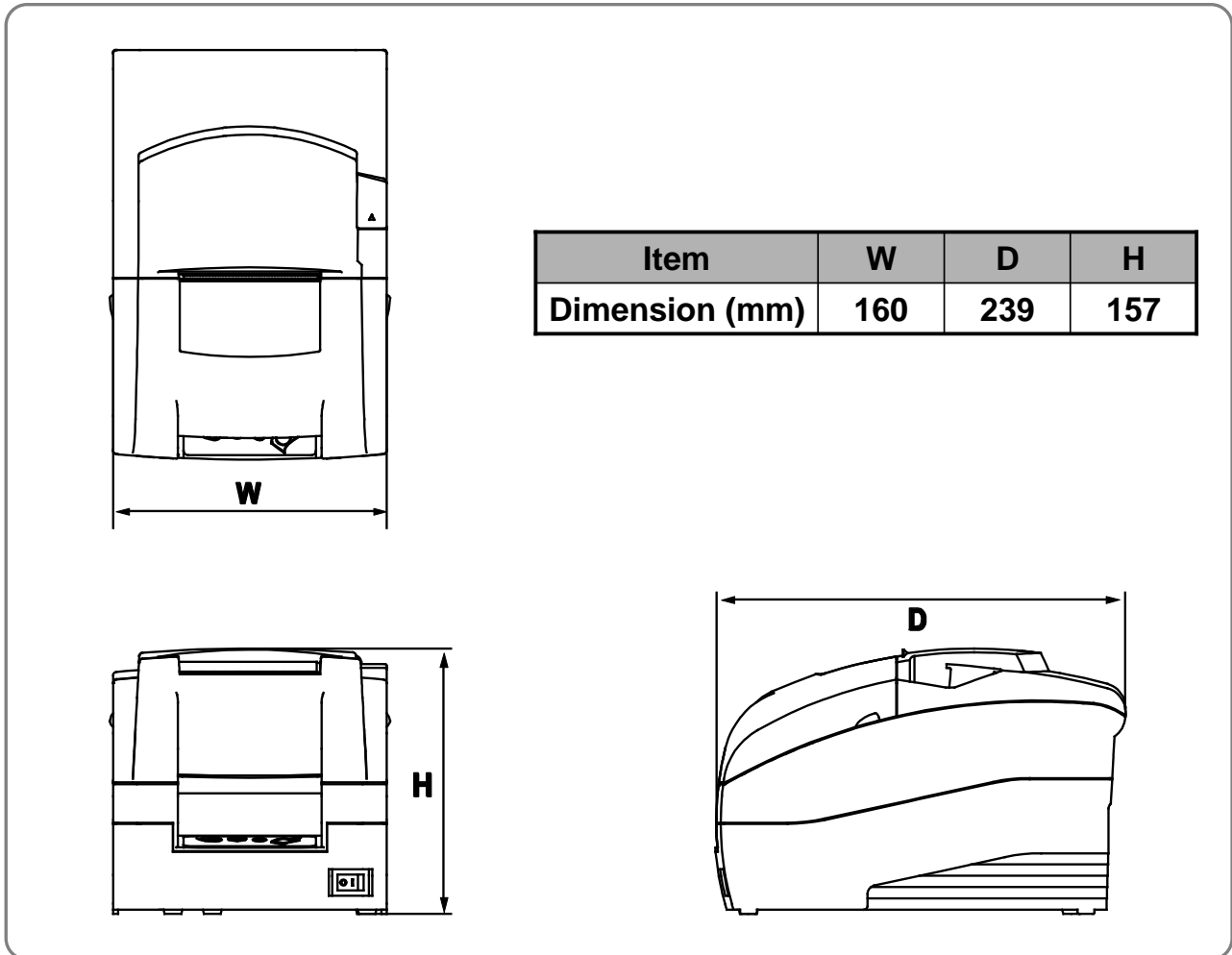

• Weight

Approx. Wt. : 2.5 kg
Shipping Wt. : 4.0 kg

9-8 Optional features

The optional features either replace a standard feature or enhance the operation of the printer.

All optional features are installed at the factory and must be selected when the printer is ordered.

• Auto cutter (SRP-275IIIA : Exclude auto cutter, SRP-275IIIC : Including auto cutter)

• Interface (OES : USB+Serial+Ethernet / OS : USB+Serial / OP : USB+Parallel)

• Cabinet color (Ivory / Dark gray)

• Black mark sensor (front /rear)

The specifications of print density for the black mark.(DensiEye 700 used)

Density print of the black mark: 1.0 or more

Density of the non-black mark: 0.1 or less

10. Appendix - Troubleshooting

This chapter gives solutions to some printer problems you may have.

10-1 ERROR LED blinking pattern

The printer stops all printer operations for the selected paper section, goes off line, and the ERROR LED blinks when an error is detected.

• Errors that automatically recover

Error	Description	ERROR LED blinking pattern	Recovery
Rear cover open error (When recoverable Error is selected)(*1)	The rear cover is opened when printing		Recovers automatically when the rear cover is closed.
Print head temperature error(*2)	The temperature of the print head is extremely high.		Recovers automatically when the print head cools.

NOTES

(*1) These conditions are selected by MSW8-5, 8-8. When MSW8-5 (mapping of the cover open status) is off, the error hasn't occurred but there is a "paper end error" instead. If MSW8-8 is off, this error is handled as an automatically recoverable error.

(*2) Print head temperature error is not abnormal.

• Recoverable errors

When a recoverable error occurs, after the cause of the error is removed, the printer can recover from the error by receiving an error recovery command without turning off the power.

Error	Description	ERROR LED blinking pattern	Recovery
Rear cover open error (*1)	The rear cover is opened when printing.		Recovers automatically when the rear cover is closed.
Auto cutter error (Type C only)	The auto cutter does not work correctly.		Recovers by error recovery command.
Home position detection error (This is "Mechanical error")	The home position cannot be detected due to a paper jam.		Recovers by error recovery command.

NOTES

(*1) These conditions are selected by MSW8-5, 8-8. When MSW8-5 (mapping of the cover open status) is off, the error hasn't occurred but there is a "paper end error" instead. If MSW8-8 is off, this error is handled as an automatically recoverable error.

• Errors that are impossible to recover

Error	Description	ERROR LED blinking pattern	Recovery
R/W error in memory or gate array	After R/W checking, the printer does not work correctly. Writing to, reading out, or erasing the NV memory for image scanning results does not work correctly.		Recovers automatically when the rear cover is closed.
High voltage error	The power supply voltage is extremely high.		Impossible to recover.
Low voltage error	The power supply voltage is extremely low.		Impossible to recover.
CPU execution error	The CPU executes an incorrect address or I/F board is not connected.		Impossible to recover.
Print head temperature detection circuit error.	There is an abnormality in the print head temperature.		Impossible to recover.

🔧 NOTES

If you see this light blinking, turn off the printer for a few seconds and then turn it back on. If the light is still blinking, call your supervisor or a service person.

10-2 The printer does not start printing

• Are any of the operation panel lights on, If no operation panel lights are on, check the following:

- Make sure that the printer is turned on.
- Make sure that the power supply cable is correctly plugged into the printer and to the power outlet.

• If any of the lights are on, please check the following:

- If the ERROR LED is on (but not blinking), the printer is off line. Check to see that the covers are closed and check the paper state. See Chapter 5 for instructions on installing or replacing the paper roll.
- If the ERROR LED is blinking, there is an error. In this case, turn off the printer for a few seconds and then turn it back on. If the light is still blinking, call your supervisor or service person.
- If the PAPER OUT LED is on, check the paper roll in the printer. See Chapter 5 for instruction on installing the paper roll.

10-3 The printer stops printing

- If the ERROR LED is on (but not blinking), the printer is off line. Check to see that the covers are closed and check the paper state. See Chapter 5 for instructions on installing or replacing the paper roll.
- If the ERROR LED is blinking, there is an error. In this case, turn off the printer for a few seconds and then turn it back on. If the LED is still blinking, call your supervisor or a service person.
- Turn off the printer and check for a paper jam. To clear paper jam, follow the steps below:
 - 1) Turn off the printer and open the rear cover of the printer.
 - 2) Remove the jammed paper and reload the paper roll as described in Chapter 5.
 - 3) Close the rear cover.
 - 4) Turn on the printer.

10-4 You want to check the operation of the printer by itself**• Self test**

Try to run the self test to check that the printer works properly. See the self test instructions in Chapter 8 to run the self test. If the self test does not work, contact your supervisor or a service person.

If the self test works properly, check the following:

- 1) Check the connection at both ends of the interface cable between the printer and the computer. Also make sure that this cable meets the specifications for both the printer and the computer.
- 2) The data transmission settings may be different between the printer and computer. Make sure that the printer's DIP Switch settings for data transmission are the same as the computer's. You can see the printer's interface settings on your self test printout.

 NOTES

If the printer still does not print, contact your dealer or a qualified service person.

10-5 Printing is poor

Check the state of ribbon cassette. If the ribbon cassette life ends, replace the ribbon cassette as described in Chapter 4.

 NOTES

If the printer is still poor, contact your dealer or a qualified service person.