



**DOT MATRIX  
LIQUID CRYSTAL DISPLAY  
MODULE**

**COMPANY NAME : 伍豐科技**

**USER MANUAL**

***SBS02002D0 Serial***

**LCD Module Description:** SBS02002D0LEW10(英日文版)  
SBS02002D0LEW20(英歐文版)  
SBS02002D0LEW30(英俄文版)

PROPOSED BY		APPROVED
Design	Approved	
		

***SDEC TECHNOLOGY CORP.***

***ADDRESS: 10F, No. 100, Shing De Rd., San Chung City 241  
Taipei Hsien, Taiwan R.O.C.***

***TEL: 886-2-2999-2512/886-2-8512-1288***

***FAX: 886-2-2999-2510/886-2-8512-2828***

***EMAIL: sdec8405@ms6.hinet.net/sdec@sdec.com.tw***

***<http://www.sdec.com.tw>***



## LCM SAMPLE APPROVAL

### (液晶顯示模組樣品確認書)

#### 1 · PART A: FILLED BY SDEC TECH (由 SDEC 填寫)

- 1) COMPANY NAME (客戶名稱) : 伍豐科技股份有限公司
- 2) SDEC ITEM NO. (產品型號) : SBS02002D0LEW10/SBS02002D0LEW20/SBS02002D0LEW30
- 3) CUSTOMER ITEM NO. (客戶產品型號) : RD9000PH03AJ/RD9000PH03AI/RD9000PH03AK
- 4) LCM Function (LCM 內容) :

A	LCD TYPE (LCD 種類) : <input type="checkbox"/> TN, <input type="checkbox"/> HTN, <input checked="" type="checkbox"/> STN, <input type="checkbox"/> FSTN ( <input type="checkbox"/> POSITIVE/正向, <input checked="" type="checkbox"/> NEGATIVE/反向, <input type="checkbox"/> BLACK MASK/內黑絲印)
B	VIEWING AREA (視角方向) : <input type="checkbox"/> 3H, <input type="checkbox"/> 6H, <input type="checkbox"/> 9H, <input checked="" type="checkbox"/> 12H
C	POLARIZER COLOR (偏光板顏色) : <input type="checkbox"/> GRAY/灰色, <input type="checkbox"/> YELLOW GREEN/黃綠色, <input checked="" type="checkbox"/> BLUE/藍色, <input type="checkbox"/> BLACK/黑色
D	BACKLIGHT COLOR (背光顏色) : <input type="checkbox"/> YELLOW GREEN/黃綠光, <input type="checkbox"/> ORANGE/橘光, <input type="checkbox"/> RED/紅光, <input type="checkbox"/> BLUE/藍光, <input type="checkbox"/> GREEN/翠綠光, <input checked="" type="checkbox"/> WHITE/白光
E	TEMPERATURE (溫度) : <input type="checkbox"/> NORMAL/常溫, <input checked="" type="checkbox"/> WIDE/廣溫
F	Rom Code CheckSum : AF37H (Check Sum is not Read Back).
G	CONTROL IC (控制 IC) : SBS02002D0LEW10 : SPLC780D1-01 SBS02002D0LEW20 : SPLC780D1-03 SBS02002D0LEW30 : SPLC780D1-02

SAMPLE DELIVERY DATE (出樣日期) : 2010.09.20

#### 2 · PART B: FILLED BY CUSTOMER (請客戶填寫)

CHECK LIST ITEMS (檢查項目) :	O K	NG	REASON (原因)
1).LCM SIZE AND THICKNESS:(LCM 尺寸及厚度):	<input type="checkbox"/>	<input type="checkbox"/>	_____
2).POLARIZER COLOR : (偏光板色澤) :	<input type="checkbox"/>	<input type="checkbox"/>	_____
3).ELECTRO CHARACTERISTIC : (電氣特性) :	<input type="checkbox"/>	<input type="checkbox"/>	_____
4).VIEWING AREA (視角範圍) :	<input type="checkbox"/>	<input type="checkbox"/>	_____
5).BACKLIGHT ILLIMINATION (背光亮度) :	<input type="checkbox"/>	<input type="checkbox"/>	_____
6).TEMPERATURE RANGE (溫度範圍) :	<input type="checkbox"/>	<input type="checkbox"/>	_____
APPROVED BY (批准) :			DATE OF APPROVAL (批准日期) :



## REVISION RECORD

Revision	Page	Contents
2008.07 2009.03A		Mass Production 1. Change Instruction Code Table 2. Add “€” Pattern in Font Table 07H & 0FH 3. PCB R15~R25:100Ω change to 0Ω
2009.05A	2 2	1. Add Customer Item No. 2. Add Rom code CheckSum. 3. PCB Rev No : Rev.3 up date to Rev.4
2010.09A	2	1. Initial Delay 30ms 2. PCB U4 : AT89C2051 change to SM894051C 3. CheckSum : AF37H

## CONTENTS

	<b>PAGE</b>
● LCM Sample Approval	2
● REVISION RECORD	3
1. Mechanical Specification	5
2. Mechanical Diagram	5
3. Interface Pin Connections	5
4. Block Diagram	5
5. Backlight Electronic Characteristics	5
6. Absolute Maximum Ratings	6
7. Electrical Characteristics	6
8. Optical Characteristics	6
9. Optical Definitions	6
10. Instruction Set	7
11. Instruction Description	8
12. User Font Patterns	11
13. Character Generator ROM Map	
13.1 SBS02002D0LEW10 Font Table	12
13.2 SBS02002D0LEW20 Font Table	13
13.3 SBS02002D0LEW30 Font Table	14
14. Reliability Condition	15
15. Function Test & Inspection Criteria	15
16. Test – Normal Temperature	18
17. Test – Wide Temperature	19
18. Precautions Against Product Handling	20
19. Warranty	21

1. Mechanical Specification

ITEM	STANDARD VALUE	UNIT
NUMBER OF CHARACTERS	20 CHARACTERS X 2 LINES	--
CHARACTER FORMAT	5 X 8 DOTS	--
MODULE DIMENSION EDGE LED BACKLIGHT	167.0 (W) X 46.0 (H) X 18.5(Max) (T)	mm
VIEWING DISPLAY AREA	123.0 (W) X 23.0 (H)	mm
ACTIVE DISPLAY AREA	118.85 (W) X 19.0 (H)	mm
CHARACTER SIZE	4.85 (W) X 9.32 (H)	mm
CHARACTER PITCH	6.00 (W) X 9.77 (H)	mm
DOT SIZE	0.93 (W) X 1.11 (H)	mm
DOT PITCH	0.98 (W) X 1.16 (H)	mm

2. Mechanical Diagram

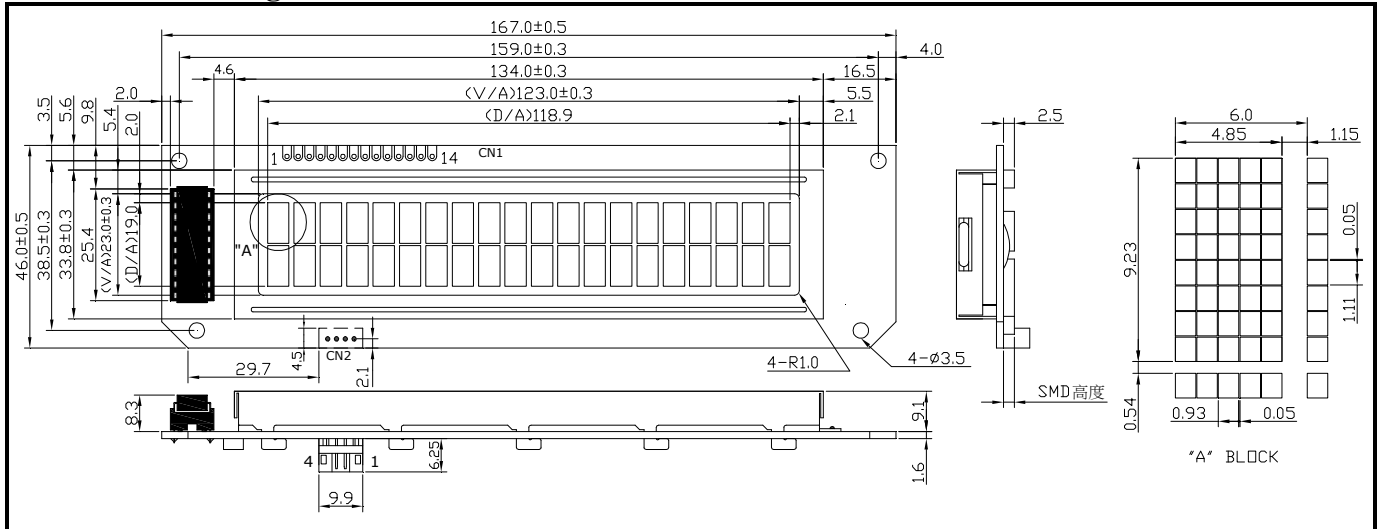

3. Interface Pin Connections(CN2)

NO	SYMBOL	FUNCTION
1	VDD	DC +5V
2	VSS	GND ( 0V)
3	DI	Series Data Input
4	FGND	FRAME GND

4. Block Diagram

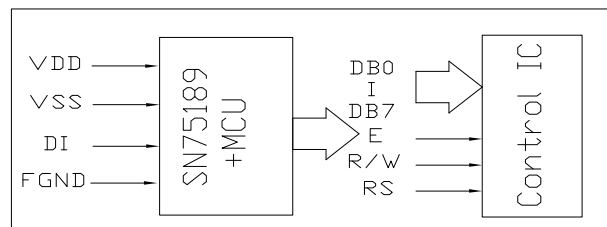

5. Backlight Electronic Characteristics

Ta=25°C

ITEM	SYMBOL	Ratings	UNIT
Absolute maximum forward current	IFm	2*80	mA
Peak forward current	IFp	2*160	mA
Reverse Voltage	Vr	4	V
Power Dissipation	Pd	2*160	mW
Operating Temperature Range	Top	-20~+70	°C
Storage Temperature Range	Tst	-30~+80	°C

ITEM	SYMBOL	MIN.	TYPE	MAX.	UNIT	CONDITION	
Forward Voltage	VF	3.8	4.0	4.2	V	IF=2*40mA	
Reverse Current	Ir	--	--	2*200	μA	Vr=4V	
Luminance	LV	500	600	--	cd/m <sup>2</sup>	IF=2*40mA	
Range		X=0.25~0.29, Y=X-0.0135~X+0.0175					IF=2*40mA
Brightness Uniformity	△	75	--	--	%	Min/Max*100%	

## 6. Absolute Maximum Ratings

ITEM		SYMBOL	MIN.	TYPE	MAX.	UNIT
INPUT VOLTAGE		VI	VSS	—	VDD	V
SUPPLY VOLTAGE FOR LOGIC		VDD-VSS	—	5.0	6.5	V
SUPPLY VOLTAGE FOR LCD		VDD-VO	—	—	6.5	V
TN HTN	NORMAL TEMPERATURE RANGE	OPERATING	0~+50	STORAGE	-10~+60	°C
	WIDE TEMPERATURE RANGE	OPERATING	-20~+70	STORAGE	-30~+80	°C
STN FSTN	WIDE TEMPERATURE RANGE	OPERATING	-20~+70	STORAGE	-30~+80	°C
STATIC ELECTRICITY		Be sure that you are grounded when handing LCM.				

## 7. Electrical Characteristics

ITEM	SYN	CONDITION	MIN.	TYPE	MAX.	UNIT
SUPPLY VOLTAGE FOR LOGIC	VDD-VSS	—	4.5	5.0	5.5	V
SUPPLY VOLTAGE FOR LCD	VDD-VO	Ta=-20°C	—	4.9	—	V
		Ta=25°C	4.1	4.3	4.5	V
		Ta=+70°C	—	3.9	—	V
INPUT HIGH VOLTAGE	VIH	—	2.2	—	VDD	V
INPUT LOW VOLTAGE	VIL	—	0	—	0.6	V
OUTPUT HIGH VOLTAGE	VOH	—	2.4	—	—	V
OUTPUT LOW VOLTAGE	VOL	—	—	—	0.4	V
SUPPLY CURRENT (Without Backlight)	IDD	VDD=+5V	—	3.0	4.5	mA

## 8. Optical Characteristics

Ta at 25°C

ITEM	SYM	CONDITION	MIN.	TYPE	MAX.	UNIT
VIEW ANGLE (TOP/BOTTOM)	$\theta 1 \sim \theta 2$	$CR \geq 5$	-35°	—	45°	deg.
VIEW ANGLE (LEFT/RIGHT)	$\varphi 1 \cdot \varphi 2$	$CR \geq 5$	-35°	—	35°	deg.
CONTRAST RATIO	CR	—	—	8	—	—
RESPONSE TIME (RISE)	TON/Tr	—	—	170	—	mS
RESPONSE TIME (DECAY)	TOFF/Tf	—	—	220	—	mS

## 9. Optical Definitions

Response Time

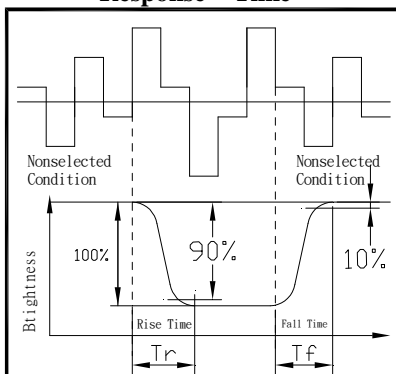

Contrast Ration

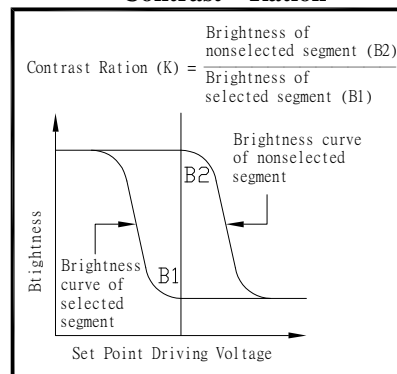

View Angle

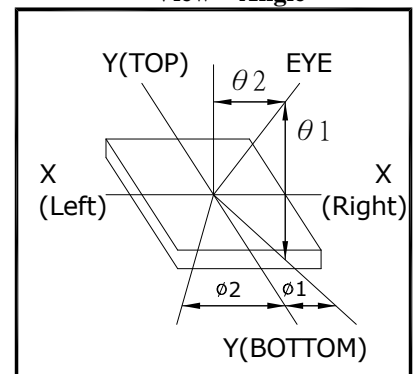

## 10. COMMAND SET

Command	Code (hex)	Description
ESC @	1B 40	Initialize.
ESC _ n	1B 5F n (n=0, 1)	Cursor hide/Show.
HT	09	Cursor right.
ESC [ C	1B 5B 43	Cursor right.
BS	08	Cursor left.
ESC [ D	1B 5B 44	Cursor left.
LF	0A	Cursor down.
ESC [ B	1B 5B 42	Cursor down.
ESC [ A	1B 5B 41	Cursor up.
ESC [ H	1B 5B 48	Cursor home
HOM	0B	Cursor home
CR	0D	Cursor left-end
ESC [ L	1B 5B 4C	Cursor left-end.
ESC [ R	1B 5B 52	Cursor right-end.
ESC [ K	1B 5B 4B	Cursor to the bottom.
ESC C n d0....d7	1B 43 n d0....d7 (00h<=n<=07h)	Create custom character patterns
ESC l x y	1B 6C x y (01h<=x<=14h, 01h<=y<=02h)	Cursor to specified position.
CLR	0C	Clear screen.
ESC Q A	1B 51 41 [datax15] 0D	Set string display mode, write string to upper line.
ESC Q B	1B 51 42 [datax15] 0D	Set string display mode, write string to lower line.
ESC DC1	1B 11	Overwrite mode
ESC DC2	1B 12	Vertical scroll mode
ESC DC3	1B 13	Horizontal scroll mode
CAN	18	Clear cursor line, clear string mode
ESC W s x1 x2 y	1B 57 s x1 x2 y S = 00h , 01h 01h<=x1<=x2<=14h, Y = 01h , 02h	Set/cancel the window range in Horizontal scroll mode

There are basically four display modes for the LCD. The user may choose the mode that is most appropriate for the application.

### Overwrite Mode:

This is the default mode. ESC DC1 and ESC @ commands would also put the Display into this mode. The cursor moves from left to right, if it is at the end of the Line, it moves to the beginning of the other line. Characters are displayed at the Current cursor position, overwriting what is originally there, the cursor is then moved to the next position.

### Vertical Scroll Mode:

If the cursor is at the upper line it behaves like the overwrite mode. When it is at the end of the lower line, the next character would scroll the content of the lower line to the upper line, the lower line is cleared and the cursor is moved to the beginning of the lower line.

### Horizontal Scroll Mode:

In this mode the cursor stays in what ever line it is at, unless changed by cursor Movement commands. When the cursor is not at the end of the line, the input Character is displayed at current cursor position, the cursor is then moved right. Once at the end of the line, subsequent character input would scroll the current Line left one position, and the new character is displayed at the end position. There is also a command, ESC W, to set display window in this mode. The effective display line would be limited within the window as defined by the command.

### String Mode:

This mode is perhaps the simplest used. The two display lines are treated independently. Only two commands, ESC Q A and ESC Q B, are needed. ESC Q A followed by a string on the upper line, left aligned. A CR (0DH) character terminates the command. If the string is less than twenty characters in length, the rest of display line is padded with plank. ESC Q B does the same for the lower display line. The only other commands active in this mode are CLR and CAN. CLR would clear the display and change the LCD into overwrite mode. CAN clears the last line that was changed and change the LCD into overwrite mode. The initialization command, ESC @, has no effect in this mode.

## 11. Instruction Description

### 11.1 ESC @ / Initialize display /

ASCII Format : ESC @

DEC Format : [027] [064]

HEX Format : [1BH][40H]

Description : Clear the data in the input buffer and reset setting to power on defaults.

### 11.2 CLR / Clear display screen, and clear string mode /

ASCII Format : CLR

DEC Format : [012]

HEX Format : [0CH]

Description : Clear all the characters displayed, clear string mode.

### 11.3 CAN / Clear cursor line, and clear string mode /

ASCII Format : CAN

DEC Format : [024]

HEX Format : [18H]

Description : Clear the line where the cursor is at, clear string mode.

### 11.4 ESC Q A d1d2d3...dn CR / Set string display mode, write string to upper line /

ASCII Format : ESC Q A d1d2d3...dn CR

DEC Format : [027][081] [065] d1d2d3...dn [013]

HEX Format : [1BH] [51H] [41H] d1d2d3...dn [0DH] {20h<=dn<=ffh , 1<=n<=20}

Description : Set string display mode, write to upper line.

The string display mode can be cancelled with CLR or CAN.

### 11.5 ESC Q B d1d2d3...dn CR / Set string display mode, write string to lower line /

ASCII Format : ESC Q B d1d2d3...dn CR

DEC Format : [027] [081][066] d1d2d3...dn [013]

HEX Format : [1BH][51H][42H] d1d2d3...dn [0DH] {20h<=dn<=ffh , 1<=n<=20}

Description : Set string display mode, write to lower line.

The string display mode can be cancelled with CLR or CAN.

### 11.6 ESC [ A / Move cursor up /

ASCII Format : ESC [ A

DEC Format : [027] [091] [065]

HEX Format : [1BH] [5BH] [41H]

Description : move the cursor up one line.

When the cursor is at the upper line, this command operates differently depending on the display mode:

- Overwrite mode: The cursor is moved to the same column on the lower line
- Vertical scroll mode: The characters displayed on the upper line are scrolled to the lower line, and the upper line is cleared. The cursor remains at the same position.
- Horizontal scroll mode: The cursor is not moved.

### 11.7 ESC [ B / Move cursor down /

ASCII Format : ESC [ B

DEC Format : [027][091][066]

HEX Format : [1BH][5BH][42H]

Description : move the cursor down one line.

When the cursor is at the lower line, this command operates differently depending on the display mode:

- Overwrite mode: The cursor is moved to the same column on the upper line.
- Vertical scroll mode: The characters displayed on the upper line are scrolled to the lower line, and the upper line is cleared. The cursor remains at the same position.
- Horizontal scroll mode: The cursor is not moved.



**11.8 ESC [ C / Move cursor right / HT**

ASCII Format : ESC [ C  
HT  
DEC Format : [027][091][067]  
[009]  
HEX Format : [1BH][5BH][43H]  
[09H]

Description : Move the cursor one position to the right.

When the cursor is at the right end, this command operates differently depending on the display mode:

- a. Overwrite mode: The cursor moves to the left end of the other line.
- b. Vertical scroll mode: When the cursor is at the upper right end, it is moved to the lower left end. When the cursor is at the lower right end, the lower line message is moved to the upper line. The lower line is cleared, and the cursor moved to the lower right end.
- c. Horizontal scroll mode: All characters on the current line are scrolled one to the left in the window. The cursor is not moved but the character area at the right end of the windows is cleared.

**11.9 ESC [ D / Move cursor left / BS**

ASCII Format : ESC [ D  
BS  
DEC Format : [027][091][068]  
[008]  
HEX Format : [1BH][5BH][44H]  
[08H]

Description : Move the cursor one position to the left.

When the cursor is at the left end, this command operates differently depending on the display mode:

- a. Overwrite mode: The cursor moves to the right end of the other line.
- b. Vertical scroll mode: When the cursor is at the lower left end, it is moved to the upper right end. When the cursor is at the upper right end, the upper line message is moved to the lower line. The upper line is cleared, and the cursor moved to the upper right end.
- c. Horizontal scroll mode: All characters on the current line are scrolled one to the right in the window. The cursor is not moved but the character area at the left end of the windows is cleared .

**11.10 ESC \_ n / Set cursor ON or OFF /**

ASCII Format : ESC \_ n  
DEC Format : [027] [095] n {0<=n<=1}  
HEX Format : [1BH] [5FH] n

Description : Set cursor ON or OFF.

When n = 0, cursor is set to OFF.

When n = 1, cursor is set to ON.

**11.11 ESC [ H / Move cursor to home position / HOM**

ASCII Format : ESC [ H  
HOM  
DEC Format : [027][091][072]  
[011]  
HEX Format : [1BH][5BH][48H]  
[0BH]

Description : Move the cursor to the left -most position on the upper line.

**11.12 ESC [ L / Move cursor to left-most position / CR**

ASCII Format : ESC [ L  
CR  
DEC Format : [027][091][076]  
[013]  
HEX Format : [1BH][5BH][4CH]  
[0DH]

Description : Move the cursor to the left-most position on the current line.

**11.13 ESC [ R / Move cursor to the right-most position /**

ASCII Format : ESC [ R

DEC Format : [027][091][082]

HEX Format : [1BH][5BH][52H]

Description : Move the cursor to the right -most position on the current line.

**11.14 ESC [ K / Move cursor to the specified position /**

ASCII Format : ESC [ K

DEC Format : [027][091][075]

HEX Format : [1BH][5BH][4BH]

Description : Move the cursor to the right -most position on the lower line.

**11.15 ESC I X Y / Move cursor to the specified position /**

ASCII Format : ESC I X Y

DEC Format : [027][108] X Y {01H<=X<=14H, 01H<=Y<=02H}

HEX Format : [1BH][6CH] X Y

Description : Move the cursor to the X-th column on the Y-th line.

**11.16 ESC W s x1 x2 y / Set or cancel the windows range at horizontal scroll mode /**

ASCII Format : ESC W s x1 x2 y

DEC Format : [027][087][000]

[027][087][001] x1 x2 y {01h<=x<=14h , 01h<=y<=02h}

HEX Format : [1BH][57H][00H]

[1BH][57H][01H] x1 x2 y

Description : Set or cancel the window range on the display screen.

When s = 0, window is cancelled.

When s = 1, window is set, where x1 and x2 set the position of the left-most and the right-most columns of the window.

y sets the upper or lower line.

The window is effective in the horizontal scroll mode.

**11.17 ESC C n d0...d7 / Create character pattern /**

ASCII Format : ESC C n d0...d7

DEC Format : [027][067] n d0...d7 {00h<=n<=07h}

HEX Format : [1BH][43H] n d0...d7

Description : Create custom character patterns.

n specifies which custom character to be generated.

d0..d7 specify the bit pattern for the character to be generated.

There are eight customer definable characters. They are numbered from 0 to 7, corresponding to character codes 00h to 07h, and are duplicated at character codes 08h to 0Fh.

**The relation between n and the character codes is as below:**

n	Char code	N	Char code
0	00h	0	08h
1	01h	1	09h
2	02h	2	0Ah
3	03h	3	0Bh
4	04h	4	0Ch
5	05h	5	0Dh
6	06h	6	0Eh
7	07h	7	0Fh

**Below is an example for generating as a custom character:**

NO	7 6 5 4 3 2 1 0 (Bit Pattern)	Data Value in hex
d0	* * * 1 1 1 1 1	1FH
d1	* * * 1 0 0 0 1	11H
d2	* * * 1 0 0 0 1	11H
d3	* * * 1 0 0 0 1	11H
d4	* * * 1 0 0 0 1	11H
d5	* * * 1 0 0 0 1	11H
d6	* * * 1 0 0 0 1	11H
d7	* * * 1 1 1 1 1	1FH

The asterisks(\*) in the bit pattern are unused bits.

To generate the above character as character 3. the following command would be sent to the display:

[1BH][43H][03H][1FH][11H][11H][11H][11H][11H][11H][1FH]

**11.18 ESC DC1 / Set overwrite mode /**

ASCII Format : ESC DC1

DEC Format : [027][017]

HEX Format : [1BH][11H]

Description : Set the display to overwrite mode. This is the default power on display mode.

**11.19 ESC DC2 / Set vertical scroll mode /**

ASCII Format : ESC DC2

DEC Format : [027][018]

HEX Format : [1BH][12H]

Description : Set the display to vertical scroll mode.

**11.20 ESC DC3 / Set horizontal scroll mode /**

ASCII Format : ESC DC3

DEC Format : [027][019]

HEX Format : [1BH][13H]

Description : Set the display to horizontal scroll mode.

**12. User Font Patterns ( CG RAM Character )**

Character Code (DD RAM data)			CG RAM Address		Character Pattern (CG RAM data)							
Hi	7 6 5 4 3 2 1 0	Lo	5 4 3	2 1 0	Hi	7 6 5	4	3	2	1	0	Lo
	0000x000		000		xxx	1	1	1	1	0		
			001		xxx	1	0	0	0	1		
			010		xxx	1	0	0	0	1		
			011		xxx	1	1	1	1	0		
			100		xxx	1	0	1	0	0		
			101		xxx	1	0	0	1	0		
			110		xxx	1	0	0	0	1		
			111		xxx	0	0	0	0	0		
	0000x001		000		xxx	1	0	0	0	1		
			001		xxx	0	1	0	1	0		
			010		xxx	1	1	1	1	1		
			011		xxx	0	0	1	0	0		
			100		xxx	1	1	1	1	1		
			101		xxx	0	0	1	1	0		
			110		xxx	0	0	1	0	0		
			111		xxx	0	0	0	0	0		
	-----		-----		-----							
	0000x111		000									
			001									
			010									
			011		111							
			100									
			101									
			110									
			111									

13.Character Generator ROM Map

13.1 SBS02002D0LEW10 (英日文版)Font Table

Higher 4 bit Lower 4 bit		CHARACTER PATTERN CHART (5x7DOTS+CURSOR)													
		0000	0010	0011	0100	0101	0110	0111	1010	1011	1100	1101	1110	1111	
Lower 4-bit (D0-D3) of Character Code (Hexadecimal)	xxxx0000	CG RAM (1)													
	xxxx0001	(2)													
	xxxx0010	(3)													
	xxxx0011	(4)													
	xxxx0100	(5)													
	xxxx0101	(6)													
	xxxx0110	(7)													
	xxxx0111														
	xxxx1000	(1)													
	xxxx1001	(2)													
	xxxx1010	(3)													
	xxxx1011	(4)													
	xxxx1100	(5)													
	xxxx1101	(6)													
	xxxx1110	(7)													
	xxxx1111														

13.2 SBS02002D0LEW20 (英歐文版)Font Table

Upper 4 bir Lower 4 bir	LLLL	LLLH	LLHL	LLHH	LHLL	LHLH	LHHL	LHHH	HLLL	HLLH	HLHL	HLHH	HHLL	HHLH	HHHL	HHHH
LLLL (00H)		±		0	0P	P	'	P	S	E	À	'	r	À	Þ	τ
LLLH (01H)		≡	!	1	A	Q	a	9	U	æ	i	'	j	†	γ	υ
LLHL (02H)		7	"	2	B	R	b	r	É	É	ó	'	ø	ø	ø	æ
LLHH (03H)		Δ	#	3	C	S	c	s	À	À	À	'	7	7	e	ψ
LHLL (04H)		r	*	4	D	T	d	t	ä	ä	é	'	4	r	z	ø
LHLH (05H)		\	%	5	E	U	e	u	à	à	é	'	†	†	†	†
LHHL (06H)		Y	&	6	F	V	f	v	à	à	#	'	u	u	u	u
LHHH (07H)	€	,	'	7	G	W	g	w	g	U	R	X	→	À	À	→
HLLL (08H)		/	(	8	H	X	h	x	é	é	÷	÷	÷	÷	÷	÷
HLLH (09H)		\	)	9	I	Y	i	y	è	è	i	Σ	Γ	Π	Λ	◄
HLHL (0AH)		*	*	#	J	Z	j	z	è	U	À	2	7	Σ	μ	¶
HLHH (0BH)		J	+	,	K	C	k	c	i	R	3	*	L	r	v	◄
HHLL (0CH)		=	,	<	L	\	l	l	i	R	8	*	u	è	z	□
HHLH (0DH)		w	-	=	M	J	m	j	i	à	8	*	u	π	π	π
HHHL (0EH)		è	.	>	N	^	n	^	À	Q	Q	T	Q	Q	p	Q
HHHH (0FH)	€	3	/	?	O	_	o	_	À	À	À	◊	◊	◊	◊	◊

13.3 SBS02002D0LEW30 (英俄文版)Font Table

Higher 4 bit Lower 4 bit		CHARACTER PATTERN CHART (5x7DOTS+CURSOR)													
		0000	0010	0011	0100	0101	0110	0111	1010	1011	1100	1101	1110	1111	
Lower 4-bit (D0-D3) of Character Code (Hexadecimal)	xxxx0000	CG RAM (1)		0	1	2	3	4	5	6	7	8	9	A	B
	xxxx0001	(2)	!	1	A	Q	a	q	r	9	w	.	U	*	
	xxxx0010	(3)	"	2	B	R	b	r	E	6	ь	u	W	*	
	xxxx0011	(4)	*	3	C	S	c	s	K	B	к	!	A	4	
	xxxx0100	(5)	*	4	D	T	d	t	3	r	ь	z	o	A	
	xxxx0101	(6)	z	5	E	U	e	u	N	e	а	ж	U	'	
	xxxx0110	(7)	g	6	F	V	f	v	A	W	W	z	W	9	
	xxxx0111		e	'	7	G	W	g	w	!3	а	!	'	*	
	xxxx1000	(1)	c	8	H	X	h	x	n	W	o	!	'	*	
	xxxx1001	(2)	.)	9	T	V	i	w	v	o	o	↑	'	*	
	xxxx1010	(3)	*	#	J	Z	j	z	o	k	а	↓	e	*	
	xxxx1011	(4)	+	#	K	C	k	w	4	а	"	*	e	*	
	xxxx1100	(5)	.	<	L	o	l	а	W	n	W	*	U	z	
	xxxx1101	(6)	-	=	M	J	m	5	B	W	c	W	*	o	
	xxxx1110	(7)	#	>	N	o	n	e	W	n	z	z	o	*	
	xxxx1111		e	/	?	O	o	e	3	T	e	.	o		

**14. Reliability Condition**

		TN Type		STN/FSTN Type	
		Normal Temp.	Wide Temp.	Normal Temp.	Wide Temp.
Viewing Angle	Horizontal ( $\Phi 1/\Phi 2$ )	$\pm 30^\circ$	$\pm 30^\circ$	$\pm 40^\circ$	$\pm 40^\circ$
	Vertical ( $\Theta 2/\Theta 1$ )	15° to 35°	15° to 35°	35° to 55°	35° to 55°
Operating Temperature		0 to 50°C	-20 to 70°C	0 to 50°C	*-20 to 70°C
Storage Temperature		-10 to 60°C	-30 to 80°C	-10 to 60°C	*-30 to 80°C
High Temperature (Power Off)		240 Hours @60°C	240 Hours @80°C	240 Hours @60°C	240 Hours @80°C
Low Temperature (Power Off)		240 Hours @-10°C	240 Hours @-30°C	240 Hours @-10°C	240 Hours @-30°C
High Temperature (Power On)		240 Hours @50°C	240 Hours @70°C	240 Hours @50°C	240 Hours @70°C
Low Temperature (Power On)		240 Hours @0°C	240 Hours @-20°C	240 Hours @0°C	240 Hours @-20°C
High Temperature & High Humidity (Power Off)		40°C/90%RH 240 Hours	40°C/90%RH 240 Hours	40°C/90%RH 240 Hours	40°C/90%RH 240 Hours
Thermal Shock 5 Cycle		A	60min@0°C	60min@-20°C	60min@0°C
		B	5min@25°C	5min@25°C	5min@25°C
		C	60min@50°C	60min@70°C	60min@50°C
LCD Lift (25°C/ 45%RH)		50,000 Hours	50,000 Hours	50,000 Hours	50,000 Hours

\*Wide temp. version may not available for some products, Please consult our sales engineer or representatives.

**15. Functional Test & Inspection Criteria**

15.1 Sample plan

Sample plan according to MIL-STD-105D level 2, and acceptance/rejection criteria is.

Base on: Major defect: AQL 0.65 Minor defect: AQL 2.5

15.2 Inspection condition

Viewing distance for cosmetic inspection is 30cm with bare eyes, and under an environment of 800 lus (20W) light intensity. All direction for inspecting the sample should be within 45° against perpendicular line.

15.3 Definition of Inspection Zone in LCD

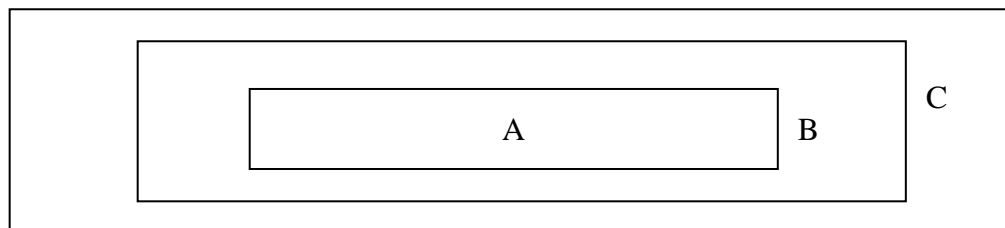

Zone A: Character / Digit area

Zone B: Viewing area except Zone A (Zone A + Zone B = minimum Viewing area)

Zone C: Outside viewing area (invisible area after assembly in customer's product)

Note: As a general rule, visual defects in Zone C are permissible, when it is no trouble for quality and assembly of customer's product.

15.4 Major Defect

All functional defects such as open (or missing segment), short, contrast differential, excess power consumption, smearing, leakage, etc. and overall outline dimension beyond the drawing. Are classified as major defects.

15.5 Inspection Parameters And Glass Pixel(偏光板和玻璃圖像檢驗)

NO	Polarizer(偏光板)	Criteria																	
1	Black or White spots And Piercing (黑/白點和刺孔)	<table border="1"> <thead> <tr> <th data-bbox="580 253 863 416">Dimension (面積)</th> <th data-bbox="863 253 1198 416">Acceptable number (可接受數量)</th> </tr> </thead> <tbody> <tr> <td data-bbox="580 416 863 468">D &lt; 0.15</td> <td data-bbox="863 416 1198 468">*</td> </tr> <tr> <td data-bbox="580 468 863 519">0.15 ≤ D ≤ 0.2</td> <td data-bbox="863 468 1198 519">4</td> </tr> <tr> <td data-bbox="580 519 863 571">0.2 ≤ D ≤ 0.25</td> <td data-bbox="863 519 1198 571">2</td> </tr> <tr> <td data-bbox="580 571 863 622">D ≤ 0.3</td> <td data-bbox="863 571 1198 622">0</td> </tr> </tbody> </table>		Dimension (面積)	Acceptable number (可接受數量)	D < 0.15	*	0.15 ≤ D ≤ 0.2	4	0.2 ≤ D ≤ 0.25	2	D ≤ 0.3	0	<p>D/面積=(Length/長度+Width/寬度)/2 =&gt; * : Disregard(忽略)</p>					
Dimension (面積)	Acceptable number (可接受數量)																		
D < 0.15	*																		
0.15 ≤ D ≤ 0.2	4																		
0.2 ≤ D ≤ 0.25	2																		
D ≤ 0.3	0																		
2	Scratch (刮傷)	<table border="1"> <thead> <tr> <th data-bbox="580 685 740 831">X(mm)</th> <th data-bbox="740 685 879 831">Y(mm)</th> <th data-bbox="879 685 1198 831">Acceptable number (可接受數量)</th> </tr> </thead> <tbody> <tr> <td data-bbox="580 831 740 882">*</td> <td data-bbox="740 831 879 882">0.04 ≥ W</td> <td data-bbox="879 831 1198 882">*</td> </tr> <tr> <td data-bbox="580 882 740 934">3.0 ≥ L</td> <td data-bbox="740 882 879 934">0.06 ≥ W</td> <td data-bbox="879 882 1198 934">4</td> </tr> <tr> <td data-bbox="580 934 740 985">2.0 ≥ L</td> <td data-bbox="740 934 879 985">0.08 ≥ W</td> <td data-bbox="879 934 1198 985">2</td> </tr> <tr> <td data-bbox="580 985 740 1037">—</td> <td data-bbox="740 985 879 1037">0.1 ≥ W</td> <td data-bbox="879 985 1198 1037">0</td> </tr> </tbody> </table> <p>X : Length(長度)    Y : Width(寬度)    * : Disregard(忽略)</p>			X(mm)	Y(mm)	Acceptable number (可接受數量)	*	0.04 ≥ W	*	3.0 ≥ L	0.06 ≥ W	4	2.0 ≥ L	0.08 ≥ W	2	—	0.1 ≥ W	0
X(mm)	Y(mm)	Acceptable number (可接受數量)																	
*	0.04 ≥ W	*																	
3.0 ≥ L	0.06 ≥ W	4																	
2.0 ≥ L	0.08 ≥ W	2																	
—	0.1 ≥ W	0																	
3	Air Bubbles (between glass & polarizer) 氣泡(玻璃跟偏光板之間)	<table border="1"> <thead> <tr> <th data-bbox="580 1077 863 1240">Dimension (面積)</th> <th data-bbox="863 1077 1198 1240">Acceptable number (可接受數量)</th> </tr> </thead> <tbody> <tr> <td data-bbox="580 1240 863 1292">D ≤ 0.15</td> <td data-bbox="863 1240 1198 1292">*</td> </tr> <tr> <td data-bbox="580 1292 863 1344">0.15 &lt; D ≤ 0.25</td> <td data-bbox="863 1292 1198 1344">2</td> </tr> <tr> <td data-bbox="580 1344 863 1395">0.25 &lt; D</td> <td data-bbox="863 1344 1198 1395">0</td> </tr> </tbody> </table> <p>* : Disregard (忽略)</p>			Dimension (面積)	Acceptable number (可接受數量)	D ≤ 0.15	*	0.15 < D ≤ 0.25	2	0.25 < D	0							
Dimension (面積)	Acceptable number (可接受數量)																		
D ≤ 0.15	*																		
0.15 < D ≤ 0.25	2																		
0.25 < D	0																		



4

Glass of Pixel  
(玻璃的圖像)

(1) Pixel shape (with Dent) / 圖像凹度

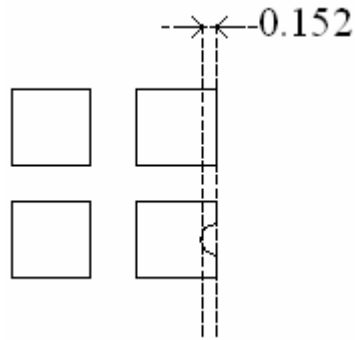

● Less than 0.152 mm is no counted  
(小於 0.152mm 者不計)

(2) Pixel shape (with Projection) / 圖像凹度

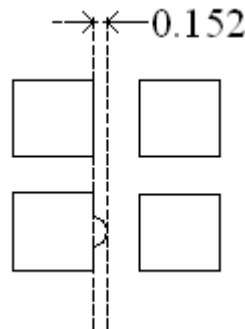

Should not be connected  
next pixel  
(點與點間不可先連接)

(3) Deformation / 變形

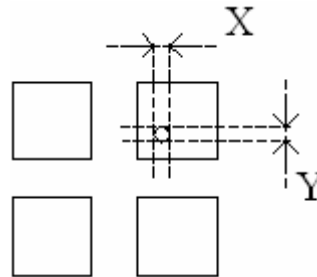

$(X + Y) / 2 \leq 0.15\text{mm}$   
● Less than 0.1 mm is no counted  
(小於 0.15mm 者不計)

(4) Deformation / 變形

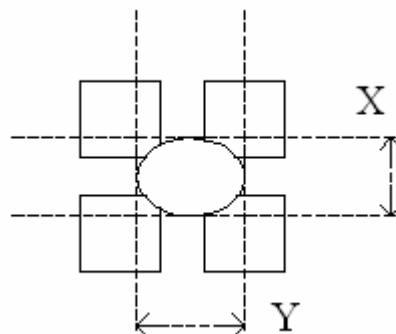

$(X + Y) / 2 \leq 0.3\text{mm}$   
● Less than 0.3 mm is no counted  
(小於 0.3mm 者不計)

**16. Test (測試條件) – Normal Temperature (常溫)**

No change no display and in operation under the following text condition.

(在不改變原先顯示下進行以下測試操作)

Conditions : Unless otherwise specified, test will be conducted under the following condition.

Temperature : 20±5 °C

Humidity : 40±5%RH

Tests will be not conducted under functioning state.

(條件：除非其他特殊情況，否則測試將以溫度：20±5 °C，濕度：40±5%RH 為主)

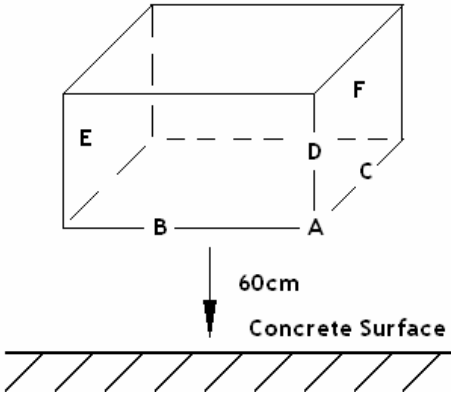
NO	Parameter	Conditions	Notes
1	High Temperature Operating	50°C±2 °C , 96 hrs (operation state) (96 小時，溫度 50°C±2 °C 電源開啟的操作情況下)	
2	Low Temperature Operating	0°C±2 °C , 96 hrs (operation state) (96 小時，溫度 0°C±2 °C 電源開啟的操作情況下)	1
3	High Temperature Storage	60°C±2 °C , 96 hrs (96 小時，溫度 60°C±2 °C 電源關閉靜態操作下)	2
4	Low Temperature Storage	-10°C±2 °C , 96 hrs (96 小時，溫度 -10°C±2 °C 電源關閉靜態操作下)	1, 2
5	Damp Proof Test	40°C±2 °C , 85 ~ 90%RH , 96hr (96 小時，溫度：40°C±2 °C，濕度：85~90%RH 電源關閉靜態操作下)	1, 2
6	Vibration Test	Total fixed amplitude : 1.5 mm (完全固定輻射：1.5mm) Vibration Frequency : 10 ~ 55 Hz (震動頻率：10~55 Hz) One cycle 60 seconds to 3 directions of X, Y, Z for each 15 minutes (每一個循環 X, Y, Z 軸方向各做 60 秒，連續做 5 次，共計 15 分鐘)	3
7	Shock Test	To be measured after dropping from 60cm high on the concrete surface in packing state. (包裝材從 60 公分高的地方向地面落下)  Dropping method comer dropping (角落落下方式) A comer : once Edge dropping (側邊落下) B, C, D edge : once Face dropping (表面落下) E, F, G face : once	

Note 1 : No dew condensation to be observed. (不要在”水氣凝結點”下觀察)

Note 2 : The function test shall be conducted after 4 hours storage at the normal

Temperature and humidity after removed from the test chamber

(從實驗室移出後，放在一般常溫 (溫度：25°C，濕度：45%RH)，

且四小時後通電流或電壓，看它是否能正常動作)

Note 3 : Vibration test will be conducted to the product itself without putting it in a container.

(在震動測試下，產品本身不需容器即能自行傳導)

**17. Test (測試條件) – Wide Temperature (廣溫)**

No change no display and in operation under the following text condition.

(在不改變原先顯示下進行以下測試操作)

Conditions : Unless otherwise specified, test will be conducted under the following condition.

Temperature : 20±5 °C

Humidity : 40±5%RH

Tests will be not conducted under functioning state.

(條件：除非其他特殊情況，否則測試將以溫度：20±5 °C，濕度：40±5%RH 為主)

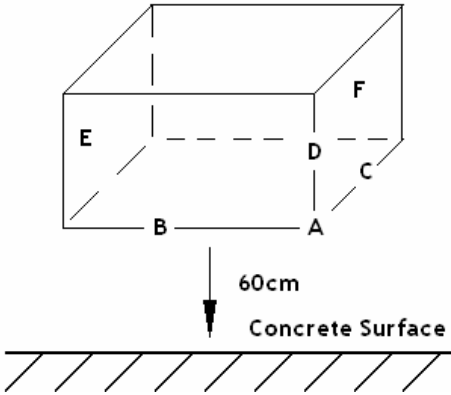
NO	Parameter	Conditions	Notes
1	High Temperature Operating	70°C±2 °C , 96 hrs (operation state) (96 小時，溫度 70°C±2 °C 電源開啟的操作情況下)	
2	Low Temperature Operating	-20°C±2 °C , 96 hrs (operation state) (96 小時，溫度-20°C±2 °C 電源開啟的操作情況下)	1
3	High Temperature Storage	80°C±2 °C , 96 hrs (96 小時，溫度 80°C±2 °C 電源關閉靜態操作下)	2
4	Low Temperature Storage	-30°C±2 °C , 96 hrs (96 小時，溫度-30°C±2 °C 電源關閉靜態操作下)	1, 2
5	Damp Proof Test	40°C±2 °C , 85 ~ 90%RH , 96hr (96 小時，溫度：40°C±2 °C，濕度：85~90%RH 電源關閉靜態操作下)	1, 2
6	Vibration Test	Total fixed amplitude : 1.5 mm (完全固定輻射：1.5mm) Vibration Frequency : 10 ~ 55 Hz (震動頻率：10~55 Hz) One cycle 60 seconds to 3 directions of X, Y, Z for each 15 minutes (每一個循環 X, Y, Z 軸方向各做 60 秒，連續做 5 次，共計 15 分鐘)	3
7	Shock Test	To be measured after dropping from 60cm high on the concrete surface in packing state. (包裝材從 60 公分高的地方向地面落下)  Dropping method comer dropping (角落落下方式) A comer : once Edge dropping (側邊落下) B, C, D edge : once Face dropping (表面落下) E, F, G face : once	

Note 1 : No dew condensation to be observed. (不要在”水氣凝結點”下觀察)

Note 2 : The function test shall be conducted after 4 hours storage at the normal

Temperature and humidity after removed from the test chamber

(從實驗室移出後，放在一般常溫 (溫度：25°C，濕度：45%RH)，

且四小時後通電流或電壓，看它是否能正常動作)

Note 3 : Vibration test will be conducted to the product itself without putting it in a container.

(在震動測試下，產品本身不需容器即能自行傳導)

## 18. Precautions Against Product Handling [產品使用注意事項]：

The following precautions will guide you in handling our product correctly.

[下列警戒引導正確地使用產品]

### 18.1 Care of the LCD module against static electricity discharge. [LCD 模組靜電注意事項]

18.1.1 When working with the module, be sure to ground your body and any electrical equipment you may be using. We strongly recommend the use of anti static mats (made of rubber), to protect work tables against the hazards of electrical shock.

[操作模組時，避免操作者身體接地及任何造成靜電的設備同時使用，強烈建議(橡膠製)抗靜電墊的使用，以免工作台面遭受到電氣干擾]

18.1.2 Slowly and carefully remove the protective film from the LCD module, since this operation can generate static electricity.

[緩慢小心地移除 LCD 模組上的保護膜，以防靜電產生]

18.1.3 Avoid the use of work clothing made of synthetic fibers. We recommend cotton clothing or other conductivity-treated fibers.

[避免穿著人造合成的工作服，建議棉質或是有傳導性的纖維質料]

### 18.2 Liquid crystal display devices (LCD devices) [液晶螢幕顯示器的組成]

18.2.1 The polarizer adhering to the surface of the LCD is made of a soft material.

Guard against scratching it. [偏光板是軟性原料製成，請勿刮傷]

18.2.2 The LCD device panel used in the LCM is made of plate glass. Avoid any strong mechanical shock. Should the glass break handle it with care.

[模組使用的玻璃為平面玻璃，避免任何強烈的機械撞擊，且觸碰時請小心]

### 18.3 When the LCD module alone must be stored form long periods of time

[當 LCD 模組須長時間存放時]

18.3.1 Protect the modules from excessive external forces. [避免外力壓迫]

18.3.2 Protect the modules from high temperature and humidity. [避免處於高溫高濕下]

18.3.3 Keep the modules out of direct sunlight or direct exposure to ultraviolet rays.

[遠離陽光曝曬或直接曝露在紫外線下]

18.4 Use the module with a power supply that is equipped with an overcurrent protector circuit, since the module is not provided with this protective feature.

[因為模組本身沒有防護，所以模組的供應器應配有過高電流的保護迴路]

18.5 Do not ingest the LCD fluid itself should it leak out of a damaged LCD module. Should hands or clothing come in contact with LCD fluid, wash immediately with soap.

[LCD 破裂液晶外漏時，切勿食下液晶；若手或衣服接觸到液晶，請立刻用肥皂清洗]

18.6 Conductivity is not guaranteed for models that use metal holders where solder connections between the metal holder and the PCB are not used. Please contact us to discuss appropriate ways to assure conductivity.

[當金屬框並沒焊接於 PCB 板上時，無法保證使用金屬框是具有傳導性，請連絡我們商討適當方式傳導]

### 18.7 For models which use CCFL [CCFL 的模組]:

18.7.1 High voltage of 1000V or greater is applied to the CCFL cable connector area.

[CCFL 排線連接器用於 1000V 以上的高電壓]

18.7.2 Protect CCFL cables from rubbing against the unit and thus causing the wire jacket to become worn. [CCFL 排線必須有保護 CCFL 與模組磨擦，以防 CCFL 外殼受到損害]

18.7.3 The use of CCFLs for extended periods of time at low temperatures will significantly shorten their service life. [長時間低溫使用 CCFL 會明顯縮減其使用壽命]

18.8 For models which use touch panels [觸控式面板模組]:

18.8.1 Do not stack up modules since they can be damaged by components on neighboring modules.  
[勿堆疊模組以防損壞]

18.8.2 Do not place heavy objects on top of the product. This could cause glass breakage.  
[勿將重物放置在產品上，會導致玻璃破損]

18.9 For models which use COG & TAB [COG 及 TAB 模組]:

18.9.1 The mechanical strength of the product is low since the IC chip is faces out unprotected from the rear. Be sure to protect the rear of the IC chip from external forces.  
[由於 IC 晶片表面無防護，所以抗壓力有限，須加強保護以防外力]

18.9.2 Given the fact that the rear of the IC chip is left exposed, in order to protect the unit from electrical damage, avoid installation configurations in which the rear of the IC chip runs the risk of making any electrical contact.  
[勿暴露 IC 晶片以防電氣干擾，且避免安裝 IC 時有任何電子接觸]

18.10 Models which use flexible cable, heat seal, or TAB [加有軟排線、熱封條或 TAB 的模組]:

18.10.1 In order to maintain reliability, do not touch or hold by the connector area.  
[以維持產品信賴度，請勿觸碰或握住連接器]

18.10.2 Avoid any bending, pulling, or other excessive force, which can result in broken connections. [避免彎曲、拉扯或過度力量，會造成連接器損壞]

18.11 In case of acrylic plate is attached to front side of LCD panel, cloudiness (very small cracks) can occur on acrylic plate, being influenced by some components generated from polarizer film.

Please check and evaluate those acrylic materials carefully before use.

[貼在 LCD 玻璃前面的壓克力板若有模糊情況(微小裂縫)，即會影響偏光板；使用前請仔細確認壓克力材質]

18.12 In case of buffer material such as cushion/gasket is assembled into LCD module, it may have an adverse effect on connecting parts (LCD panel-TCP/ HEAT SEAL/ FPC, PCB-TCP/HEAT SEAL/FPC, TCP-HEAT SEAL, TCP-FPC, HEAT SEAL-FPC) depending on its materials.

Please check and evaluate these materials carefully before use.

[緩衝原料像是減震墊/襯墊，或許會對連接器(LCD panel-TCP/ HEAT SEAL/ FPC, PCB-TCP/HEAT SEAL/FPC, TCP-HEAT SEAL, TCP-FPC, HEAT SEAL-FPC)造成反效果，使用前請仔細確認材料]

## 19. Warranty [保證]:

This product has been manufactured to your company's specifications as a part for use in your company's general electronic products. It is guaranteed to perform according to delivery specifications. For any other use apart from general electronic equipment, we cannot take responsibility if the product is used in medical devices, nuclear power control equipment, aerospace equipment, fire and security systems, or any other applications in which there is a direct risk to human life and where extremely high levels of reliability are required. If the product is to be used in any of the above applications, we will need to enter into a separate product liability agreement.

[此產品的製造是依照客戶的規格，被使用於客戶的一般電子產品上，保證產品製作根據出貨的規格，若產品的使用不是在一般電子設備，而組裝於下列產品上則無法受理（如醫療產品、核心電源控制設備、航空設備、防火及保全系統，或任何相關儀器會直接影響人類生命等），若模組使用於上述的儀器，則需商討各別產品責任義務的協定]

- 19.1 We cannot accept responsibility for any defect, which may arise after the application of strong external force to the product.  
[不受理因強大外力衝擊造成產品的缺陷]
- 19.2 We cannot accept responsibility for any defect, which may arise from additional manufacturing of the product (including disassembly and reassembly), after product delivery.  
[不受理產品出貨後，因額外加工(包含拆裝及重新封包)造成的缺陷]
- 19.3 We cannot accept responsibility for any defect, which may arise due to the application of static electricity after the product, has passed your company's acceptance inspection procedures.  
[不受理通過貴公司檢驗流程後，由於靜電造成產品的缺陷]
- 19.4 We cannot accept responsibility for intellectual property of a third party, which may arise through the application of our product to your assembly with exception to those issues relating directly to the structure or method of manufacturing of our product.  
[不受理因在客戶產品生產線端所產生的第三人智慧財產權責任，除非與我司生產製造方法有直接關係的問題]
- 19.5 When the product is in CCFL models, CCFL service life and brightness will vary according to the performance of the inverter used, leaks, etc. We cannot accept responsibility for product performance, reliability, or defect, which may arise.  
[產品是 CCFL 模組時，CCFL 的壽命及亮度將取決於連接器的性能、漏電量等；無法受理因 CCFL 造成產品性能的缺陷]
- 19.6 SDEC will not be held responsible for any quality guarantee issue for defect products longer than 1(one) year from SDEC production which ever comes later.  
[出廠超過一年的瑕疵品，任何品質擔保則不受理]